

TRIGANO

TRIGANO JARDIN

Le Boulay
41170 – Cormenon, France

Carport Mistral Double

J-87902P1

2x  **5 x 2.8 x 2.1 m**

ou

1x  **6 x 3,4 x 2,1 m**

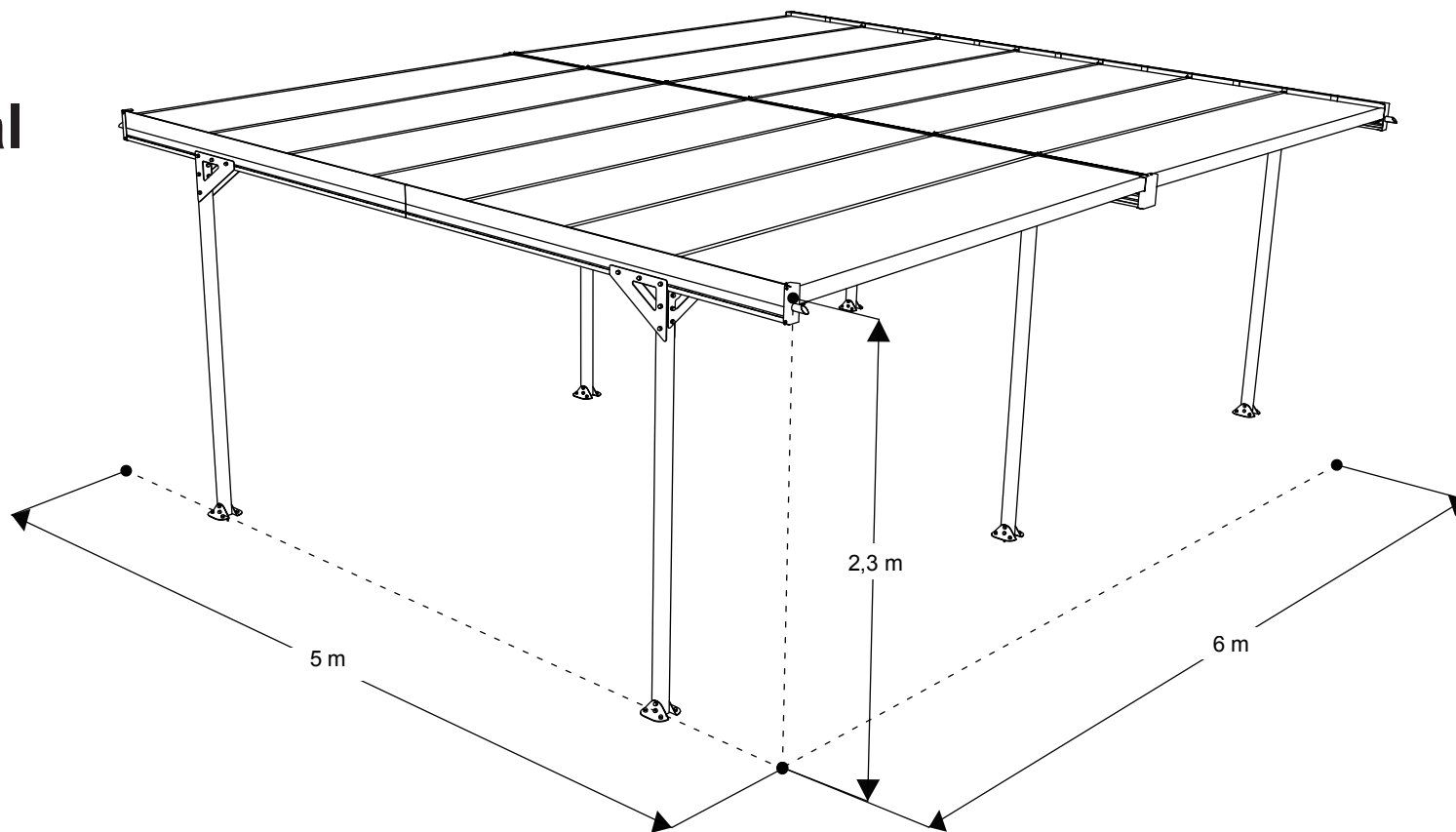

90 km/h



10 cm

J-123190-C

1

40

Madame, Monsieur,

Nous tenons à vous féliciter et à vous remercier pour l'acquisition de produit conçu et réalisé par TRIGANO JARDIN. Pour qu'il soit utilisé dans les meilleures conditions possibles de sécurité, nous vous demandons d'accorder toute votre attention aux différents conseils ci-dessous et de vous reporter aux figures correspondantes qui se situent dans les pages suivantes.

Conservez soigneusement cette notice de montage qui pourrait vous être utile dans l'avenir.

Avec nos remerciements et nos sentiments dévoués,

La Société TRIGANO JARDIN,

Michel ESNAULT - Directeur Général.

IMPORTANT

- Veuillez lire attentivement les instructions avant de procéder à l'assemblage de votre produit.
- Veuillez suivre attentivement et dans l'ordre les différentes étapes.
- Conservez les instructions pendant la durée de vie du produit
- Résistance maximale au vent : 90 km/h
- Résistance maximale à la neige : 10 cm

SECURITE

- Trier les pièces et vérifier la liste du contenu avant d'entreprendre le montage.
- Pour des raisons de sécurité, ce produit doit être monté par quatre personnes minimum.
- Quelques pièces ont des bords agressifs. Faites attention lors de la manipulation, portez toujours des gants lors de l'assemblage.
- N'essayez pas d'assembler le produit dans des conditions venteuses ou pluvieuses.
- Tenez tous les sacs plastiques hors de portée des enfants
- Eloignez les enfants de la zone d'assemblage
- Evitez d'assembler le produit si vous êtes fatigué, sous traitement médicamenteux ou sous l'emprise d'alcool ou souffrez d'étourdissements.
- Si vous utilisez une échelle ou des outils électriques, veuillez suivre les conseils de sécurité du fabricant.
- Ne pas grimper ou ne pas se tenir sur la toiture.
- Ce produit a été conçu et produit pour être utilisé exclusivement comme abri pour voiture.
- Resserrez toutes les vis en fin de montage.

INSTALLATION

- Veuillez consulter les autorités locales pour vérifier si des permis sont requis pour installer le produit.
 - Cet article doit être soigneusement installé sur un terrain plat et horizontal sous peine de déséquilibre et/ ou renversement.
 - L'ancrage du produit au sol est obligatoire pour assurer la stabilité et la rigidité du produit, ainsi que d'assurer la garantie.
 - Pendant l'assemblage, utilisez des éléments souples comme le carton d'emballage sous les pièces afin d'éviter les rayures et endommagements.
 - Choisissez un emplacement à l'abri des vents dominants et des sources d'accumulation de neige (toiture, arbres...)
- Ce produit devra être assemblé sur une base solide (comme du béton ou de l'asphalte).
- **Etape FONDATION** : La quantité totale de béton à verser est de 0,4m3 (6x 0,064m3).
 - **Etapes 15, 22 et 23** : Serrer les écrous pour maintenir les traverses en position.
 - **Etape 18** : 4 personnes sont nécessaires pour soulever la toiture et mettre les pieds « J-150910 ».
 - **Etapes 20 et 24** : Retirer les films de protection puis appliquer du ruban adhésif sur les flancs ouvert du polycarbonate.
 - **Etapes 20 et 24** : Veuillez installer la face traitée anti-UV des panneaux polycarbonate vers le ciel. La face traitée anti-UV est protégée par un film avec des inscriptions.
 - **Etape 22** : 4 personnes sont nécessaires pour mettre en place et fixer les traverses « J-150919 ».
 - **Etapes ANCRAGE** : Vérifier l'équerrage des pieds avec le niveau à bulle avant l'ancrage du produit.
 - **Etapes ANCRAGE** : Pour fixer le produit au sol, il faut :
 - Percer des trous de Ø8 dans le béton à l'emplacement des trous des pieds de fixation du produit;
 - Enfoncer avec un marteau les goujons d'ancrage «J-121374» dans les trous;
 - Visser les goujons d'ancrage.

MAINTENANCE

- Ce produit n'est pas une charpente, ne pas monter sur le toit.
- Veuillez conserver la toiture et les gouttières en parfait état de propreté (neige, saleté, feuilles). Une grosse quantité de neige sur la toiture peut endommager le produit et le rendre dangereux.
- Nettoyer votre produit à l'eau claire ou avec des produits au PH neutre, spécifiquement sur les panneaux de toiture
- Couleur de peinture RAL : 7016
- Vérifiez régulièrement le serrage des vis du produit.

SAV

Le service après vente remplace uniquement les pièces manquantes et/ ou défectueuses et en aucun cas la totalité de l'article.

Selon la durée de garantie des pièces et la période depuis l'achat du produit, il est demandé à l'acheteur de payer un pourcentage du prix de revient des pièces selon le tableau ci-dessous.

Pourcentage de prise en charge par la société	Pourcentage de prise en charge par le client
100%	Remplacement gratuit de la pièce
60%	40%
50%	50%
40%	60%
30%	70%
20%	80%
10%	90%

- Les pièces éventuellement manquantes dans le colis initial sont fournies gratuitement sous réserve que la réclamation soit faite dans les deux mois suivant l'achat du produit.
- Les demandes d'indemnisation (quelle qu'en soit la forme) ne sont pas admises.
- Il ne sera admis aucun retour de marchandise, sauf accord et demande spécifique de notre part.
- Tout produit défectueux devra être tenu à disposition pendant 1 mois, celui-ci pourra faire l'objet d'une reprise pour expertise par nos soins.
- Il n'est pas possible de modifier le produit d'origine (par exemple l'ajout d'un accessoire). Seules, les pièces de rechange TRIGANO JARDIN doivent être utilisées. Pour toute demande de SAV, veuillez-vous connecter à l'adresse suivante : <http://sav.triganojardin.com>

GARANTIE

Pour bénéficier de votre garantie, veuillez conserver cette notice ainsi qu'une preuve d'achat.

En cas de problème sur votre produit, rendez-vous sur notre site internet <http://sav.triganojardin.com>.

1. Conditions:

- La garantie couvre un défaut de fabrication ou un non fonctionnement du produit dans le cadre de son utilisation normale.
- Les garanties ne seront valides que si le produit est installé, utilisé et entretenu conformément aux instructions présentes dans la notice.
- Toute mauvaise manipulation et toute modification du produit autre que ceux prévu dans la notice annulent toutes les garanties.
- Les garanties ne couvrent pas les dommages causés par des intempéries (tempête, grêle, inondation...) ou tout autre cas de force majeure (incendie, vandalisme...).

2. Exclusions

- Mauvais montage, installation, utilisation et / ou défaut d'entretien.
- Trous, micro perforations ou déchirures accidentelles consécutifs au montage ou à l'utilisation
- Non respect des recommandations et consignes indiquées sur la notice de montage et sur la lettre de recommandations.
- Non respect des consignes de scellement du produit avant utilisation.
- Modifications sur produits ainsi que les détériorations dues aux intempéries (pluie, neige, grêle, vent).

3. Durée:

- Les pièces en aluminium sont garanties 15 ans dégressifs selon le tableau ci-dessous.
- Les plaques de polycarbonate sont garanties 10 ans dégressifs selon le tableau ci-dessous.
- Les pièces de jonction en acier sont garanties 2 ans selon le tableau au dessous.

Durée de garantie	Nombre d'année depuis l'achat du produit														
	2	3	4	5	6	7	8	9	10	11	12	13	14	15	
2 ans	100 %														
10 ans	100 %	50 %	30 %	30 %	20 %	20 %	20 %	20 %	10 %						
15 ans	100 %	60 %	50 %	50 %	40 %	40 %	30 %	30 %	20 %	20 %	20 %	10 %	10 %	10 %	

Dear Customer,

Congratulations on your purchase! We would like to thank you for choosing the Carport Mistral, designed and manufactured by TRIGANO JARDIN. To ensure that this product is used in the safest possible conditions, we recommend that you pay careful attention to the guidelines below and that you refer to the diagrams on the following pages. Please keep these assembly instructions in a safe place for future reference.

Sincere thanks and best regards,
TRIGANO JARDIN,
Michel ESNAULT - Chief Executive Officer.

IMPORTANT

- Please read these instructions carefully before starting to assemble the carport.
- Please carry out the steps carefully and in the order set out in these instructions.
- Please keep these instructions in a safe place throughout the lifespan of the carport
- Maximum wind resistance: 90 km/h
- Maximum snow resistance: 10 cm

SAFETY

- Sort the parts and check them against the list of contents before assembling.
- For safety purposes we recommend this product be assembled by at least four persons.
- Some parts have sharp metal edges. Handle the components with care, and always wear gloves during assembly.
- Do not attempt to assemble the product in windy or wet conditions.
- Always keep plastic bags out of reach of children.
- Keep children away from the assembly area.
- Do not attempt to assemble the carport if you are tired, have taken medication, are under the influence of alcohol or if you are prone to dizzy spells.
- When using a stepladder or power tools, ensure that you follow the manufacturer's safety advice.
- Do not climb or stand on the roof.
- This product was designed and produced to be used as a carport only.
- Securely fasten all screws once the carport is assembled.

INSTALLATION

- Please consult your local building authorities to know if planning permission is required to erect the carport in your area.
- The carport must be installed on flat, levelled ground to ensure stability and avoid risk of structural collapse.
- The carport must be anchored to the ground to ensure structural stability and rigidity, and to ensure warranty coverage.
- During assembly place a soft surface below the parts, such as the product packaging, to avoid scratches and damage.
- Choose a location protected from prevailing winds and snow accumulation (roofs, trees...)

This carport must be assembled on a solid base (such as concrete or asphalt).

- **FOUNDATION Step** : The total quantity of concrete required is 0.4m³.
- **Steps 15, 22 and 23** : Fasten the nuts to maintain the rails in position.
- **Step 18** : You have to be 4 persons to lift the roof and to put the feet "J-150910".
- **Steps 20 and 24** : Remove the protective film and place vent tape along the open ends of the polycarbonate roofing panels.
- **Steps 20 and 24** : Install the polycarbonate roofing panels with the anti-UV side facing up towards the sun. The anti-UV side is marked with a protective printed film.
- **Step 22** : You have to be 4 persons to set up and fix the crosspieces "J-150919".
- **ANCHORING Steps** : Before anchoring the product, check that the legs are perfectly levelled, vertically and horizontally.
- **ANCHORING Steps** : Secure the carport to the ground as follows:
 - Drill Ø8 holes into the concrete base for each of the bolt-down post support holes;
 - Hammer the "J-121374" anchor studs into the holes;
 - Fasten the anchor studs.

MAINTENANCE

- This carport is not a roof structure, do not climb onto the top.
- Always keep the roof and gutters clean of snow, dirt and leaves. Heavy amounts of snow may damage the carport and make it unsafe.
- Always use clear water or mild, PH neutral detergent solutions, to clean the carport and especially the roof panels.
- RAL paint code: 7016.
- The fastening of the bolts must be checked regularly.

Customer Service

- Our customer service will only replace missing and/or faulty parts and will under no circumstances replace the product in its entirety.
- Depending on the warranty period for specific parts and the product purchase date, the customer will be expected to pay a percentage of the cost price of parts as listed in the table below.

Percentage covered by the company	Percentage covered by the customer
100%	Free of charge parts replacement
60%	40%
50%	50%
40%	60%
30%	70%
20%	80%
10%	90%

- Any parts found to be missing from the original packaging will be supplied free of charge, provided that the claim is made within two months of the product purchase date.
- Claims for compensation (in whatever form) will not be accepted.
- No product returns will be accepted, unless expressly requested and agreed to by us.
- Any defective products must be kept available for a period of 1 month, as we may request them to be returned for inspection purposes.
- Do not attempt to modify the original product (for example by adding an attachment). Only TRIGANO JARDIN replacement parts should be used. For any Customer Service enquiries please consult the following website: <http://sav.triganojardin.com>

WARRANTY

For any warranty claims, please keep these assembly instructions and your proof of purchase safely. For any problems relating to your carport, please go to our website <http://sav.triganojardin.com>.

1. Conditions:

- The warranty will cover any manufacturing defects or product malfunctioning within normal use.
- The warranty will only be valid if the product is installed, used and maintained in accordance with these assembly instructions.
- Any misuse or modification of the product other than that authorised in the assembly instructions will void all warranties.
- The warranty does not cover any damages caused by bad weather conditions (storm, hail, flood...) or any other force majeure (fire, vandalism...).

2. Exclusions

- Incorrect assembly, installation, use and/or lack of maintenance.
- Holes, micro perforations or accidental tears resulting from assembly or usage
- Failure to comply with the recommendations and instructions detailed in the assembly instructions and management letter.
- Failure to comply with the instructions for sealing the product before use.
- Any modifications to the products or deterioration resulting from adverse weather conditions (rain, snow, hail, wind).

3. Warranty period:

- The aluminium parts have a 15 year decreasing rates warranty period, see table below.
- The polycarbonate panels have a 10 year decreasing rates warranty period, see table below.
- The stainless steel connector fittings have a 2 year warranty period, see table below.

Warranty period	Number of years since the product purchase date														
	2	3	4	5	6	7	8	9	10	11	12	13	14	15	
2 years	100 %														
10 years	100 %	50 %	30 %	30 %	20 %	20 %	20 %	20 %	10 %						
15 years	100 %	60 %	50 %	50 %	40 %	40 %	30 %	30 %	20 %	20 %	20 %	10 %	10 %	10 %	

Sehr geehrte Kundin, sehr geehrter Kunde,
 wir möchten Sie zum Kauf Ihres von TRIGANO JARDIN konzipierten und gefertigten Produkts beglückwünschen und uns herzlich bei Ihnen bedanken. Damit es unter den bestmöglichen Sicherheitsbedingungen genutzt wird, bitten wir Sie, die nachfolgenden diversen Sicherheitshinweise aufmerksam zu lesen und die entsprechenden Abbildungen auf den folgenden Seiten zu beachten. Bitte bewahren Sie diese Montageanleitung sorgfältig auf, sie kann auch in Zukunft hilfreich sein.
 Besten Dank und freundliche Grüße,
 Die Firma TRIGANO JARDIN,
 Michel Esnault - Geschäftsführer.

WICHTIG

- Bitte lesen Sie die Anweisungen aufmerksam durch, bevor Sie mit der Montage des Produkts beginnen.
- Bitte befolgen Sie die verschiedenen Etappen genau und halten Sie die Reihenfolge ein.
- Bewahren Sie die Anleitung über die gesamte Lebensdauer des Produkts auf.
- Maximale Windbeständigkeit: 90 km/h
- Max. Schneelast: 10 cm

SICHERHEIT

- Sortieren Sie die Teile und prüfen Sie die Teileliste, bevor Sie mit dem Aufbau beginnen.
- Aus Sicherheitsgründen muss dieses Produkt mindestens von vier Personen aufgebaut werden.
- Manche Teile haben scharfkantige Ränder. Seien Sie vorsichtig bei der Handhabung, tragen Sie beim Zusammenbau stets Handschuhe.
- Versuchen Sie nicht, das Produkt bei Wind oder Regen aufzubauen.
- Alle Plastikverpackungen müssen außerhalb der Reichweite von Kindern aufbewahrt werden
- Kinder dürfen sich nicht im Montagebereich aufhalten.
- Sie sollten das Produkt nicht aufbauen, wenn Sie müde sind, unter medikamentöser Behandlung stehen, unter Alkoholeinfluss stehen oder Ihnen schwindelig ist.
- Falls Sie eine Leiter oder Elektrowerkzeuge verwenden, beachten Sie bitte die Sicherheitshinweise des jeweiligen Herstellers.
- Nicht auf das Dach steigen bzw. auf dem Dach stehen.
- Dieses Produkt wurde ausschließlich dazu konzipiert und gefertigt, um als Carport genutzt zu werden.
- Ziehen Sie alle Schrauben fest, sobald Sie die Montage beendet haben.



INSTALLATION

- Wenden Sie sich an die lokalen Behörden, um zu prüfen, ob für die Installation des Produkts Genehmigungen erforderlich sind.
- Dieser Artikel muss sorgfältig auf einem flachen und waagrechten Untergrund installiert werden, ansonsten besteht die Gefahr, dass er instabil ist und/oder umkippt.
- Die Bodenverankerung ist obligatorisch, damit das Produkt stabil und fest auf dem Boden steht und damit bei Bedarf Garantieansprüche geltend gemacht werden können.
- Legen Sie bei der Montage weiche Unterlagen wie Verpackungsmaterial aus Karton unter die Teile, um Kratzer und Beschädigungen zu vermeiden.
- Wählen Sie einen windgeschützten Standort aus, an dem es keine Möglichkeiten für Schneeanlagerungen gibt (Dächer, Bäume etc.).
- Dieses Produkt muss auf einem festen Untergrund montiert werden (wie Beton oder Asphalt).
- **FUNDAMENT SCHRITT** : Insgesamt muss 0.4 m3 Beton gegossen werden.
- **Schritte 15, 22 und 23** : Ziehen Sie die Muttern fest, damit die Querräger in Position bleiben.
- **Schritt 18** : Sie müssen 4 Personen sein, um das Dach anzuheben und die Füße „J-150910“ zu stellen.
- **Schritte 20 und 24** : Entfernen Sie die Schutzfolien, kleben Sie anschließend Klebeband auf die offenen Polycarbonat-Flanken.
- **Schritt 20 und 24** : Bitte montieren Sie die UV-stabilisierte Seite der Polycarbonat-Platten so, dass Sie Richtung Himmel zeigt.
- Die UV-stabilisierte Seite ist mit einer beschrifteten Folie geschützt.
- **Schritt 22** : Sie müssen 4 Personen sein, um die Querräger „J-150919“ aufzustellen und zu befestigen.
- **Schritte VERANKERUNG** : Prüfen Sie die Rechtwinkligkeit der Füße mit der Wasserwaage, bevor Sie das Produkt verankern.
- **Schritte VERANKERUNG** : Für die Bodenbefestigung des Produkts müssen Sie:
 - An der Stelle, wo sich die Löcher in den Befestigungsfüßen des Produkts befinden, Löcher mit Ø8 in den Beton bohren.
 - Die Steckanker „J-121374“ mit einem Hammer in den Löchern versenken.
 - Schrauben Sie die Steckanker fest.

WARTUNG

- Dieses Produkt ist kein Dachtragwerk, nicht auf das Dach steigen.
- Bitte halten Sie die Überdachung in einwandfrei sauberem Zustand (Schnee, Schmutz, Blätter). Große Schneemengen auf dem Dach können das Produkt beschädigen und es unsicher machen.
- Reinigen Sie Ihr Produkt mit klarem Wasser oder mit pH-neutralen Mitteln, insbesondere auf den Dachplatten.

- Anstrichfarbe RAL: 7016
- Prüfen Sie regelmäßig, ob die Schrauben des Produkts festgezogen sind.

KUNDENDIENST

- Der Kundendienst ersetzt ausschließlich fehlende und/oder defekte Teile und in keinem Fall das gesamte Produkt.
- Je nach Garantiedauer der Teile und Zeitraum, der seit dem Kauf verstrichen ist, wird der Käufer gebeten, einen Prozentsatz des Herstellungspreises der Teile entsprechend nachstehender Tabelle zu bezahlen.

Prozentsatz, der von der Firma übernommen wird	Prozentsatz, der vom Kunden übernommen wird
100%	Kostenloser Austausch des Teils
60%	40%
50%	50%
40%	60%
30%	70%
20%	80%
10%	90%

- Eventuell fehlende Teile in der Originalverpackung werden kostenlos nachgeliefert, sofern die Reklamation innerhalb zwei Monate nach dem Kauf des Produkts erfolgt.
- Entschädigungsanfragen (in welcher Form auch immer) sind nicht zulässig.
- Produktrücksendungen sind nicht zulässig, außer es liegt eine Genehmigung oder eine spezielle Aufforderung unsererseits vor.
- Sämtliche defekte Teile müssen 1 Monat zur Verfügung gestellt werden, diese können für eine von uns vorgenommene Fehlerdiagnose zurückgefordert werden.
- Das ursprüngliche Produkt kann nicht verändert werden (z. B. Hinzufügen weiterer Elemente). Es dürfen ausschließlich Ersatzteile von TRIGANO JARDIN verwendet werden. Für Fragen an den Kundendienst loggen Sie sich bitte auf folgender Seite ein: <http://sav.triganojardin.com>

GARANTIE

Damit Sie die Garantieleistungen in Anspruch nehmen können, bewahren Sie bitte diese Anleitung sowie einen Kaufbeleg auf.
 Bei Problemen mit Ihrem Produkt besuchen Sie sich bitte unsere Website <http://sav.triganojardin.com>.

1. Bedingungen:

- Die Garantie deckt Herstellungsfehler oder Defekte des Produkts im Rahmen der normalen Verwendung.
- Garantieansprüche können nur geltend gemacht werden, wenn das Produkt gemäß den Hinweisen dieser Anleitung installiert, genutzt und gewartet wird.
- Unsachgemäße Handhabungen und Änderungen des Produkts, die nicht in dieser Anleitung vorgesehen sind, heben die Garantieansprüche auf.
- Die Garantie gilt nicht für Schäden, die durch Unwetter entstanden sind (Sturm, Hagel, Überschwemmung etc.) oder für sonstige Fälle höherer Gewalt (Feuer, Vandalismus etc.).

2. Garantieausschlüsse

- Unsachgemäße Montage, Installation und/oder Verwendung und/oder mangelhafte Instandhaltung.
- Löcher, kleine Perforierungen oder versehentlich verursachte Risse, die in Folge der Montage oder des Gebrauchs entstehen.
- Nichtbefolgung der Empfehlungen und Hinweise dieser Montageanleitung und dieser Produktempfehlung.
- Nichtbeachtung der Hinweise für die Bodenverankerung des Produkts vor seinem Gebrauch.
- Produktänderungen sowie Beschädigungen durch Unwetter (Regen, Schnee, Hagel, Wind).

3. Dauer:

- Die Aluminiumteile haben entsprechend der nachstehenden Tabelle eine Garantie von 15 Jahren (degressiv).
- Die Polycarbonat-Platten haben entsprechend der nachstehenden Tabelle eine Garantie von 10 Jahren (degressiv).
- Die Verbindungsteile aus Stahl haben entsprechend der nachstehenden Tabelle eine Garantie von 2 Jahren.

Garan-tiedauer	Anzahl der Jahre seit dem Kauf des Produkts														
	2	3	4	5	6	7	8	9	10	11	12	13	14	15	
2 Jahre	100 %														
10 Jahre	100 %	50 %	30 %	30 %	20 %	20 %	20 %	20 %	10 %						
15 Jahre	100 %	60 %	50 %	50 %	40 %	40 %	30 %	30 %	20 %	20 %	20 %	10 %	10 %	10 %	

Estimado/a señor/a:

Le felicitamos y le damos las gracias por haber adquirido un producto diseñado y fabricado por TRIGANO JARDIN. Para utilizarlo en condiciones adecuadas de seguridad, le aconsejamos que se familiarice con las recomendaciones que se incluyen a continuación y con las imágenes correspondientes que encontrará en las páginas adjuntas. Guarde las instrucciones de montaje, podrían resultarle útiles más adelante.

Gracias de nuevo. Reciba un cordial saludo:

La Sociedad TRIGANO JARDIN,
Michel Esnault - Director general.

IMPORTANTE

- Lea atentamente las instrucciones antes de proceder al montaje de su producto.
- Siga con atención y en el orden indicado las diferentes etapas.
- Conserve las instrucciones durante toda la vida útil del producto.
- Resistencia máxima al viento: 90 km/h
- Resistencia máxima a la nieve: 10 cm

SEGURIDAD

- Separe las piezas y compruebe la lista del contenido antes de iniciar el montaje.
- Por motivos de seguridad, este producto deben montarlo cuatro personas como mínimo.
- Algunas piezas tienen bordes afilados. Vaya con cuidado al manipularlas. Durante el montaje, utilice guantes en todo momento.
- No intente montar el producto con mucho viento o lluvia.
- Mantenga todas las bolsas de plástico lejos del alcance de los niños.
- Aleje a los niños de la zona de montaje.
- Evite montar el producto si presenta signos de cansancio, está en tratamiento médico, se encuentra bajo los efectos del alcohol o si sufre mareos.
- Si utiliza una escalera o herramientas eléctricas, respete las advertencias de seguridad del fabricante.
- No trepe ni se cuelgue en el techo.
- Este producto se ha diseñado y fabricado únicamente para que se utilice como cobertizo para coches.
- Vuelva a apretar todos los tornillos al finalizar el montaje.



INSTALACIÓN

- Consulte con las autoridades locales para comprobar si es necesario pedir algún permiso para instalar el producto.
- Este artículo debe instalarse cuidadosamente en un terreno llano y horizontal. En caso contrario, existe el riesgo de que no esté equilibrado y/o de que vuelque.
- El anclaje del producto al suelo es obligatorio para garantizar la estabilidad y la firmeza del producto y para asegurar la garantía.
- Durante el ensamblaje, coloque elementos flexibles como el cartón de embalaje bajo las piezas al objeto de evitar arañazos y daños.
- Elija una ubicación resguardada de los vientos dominantes y de las fuentes de acumulación de nieve (techumbre, árboles...).

Este producto deberá ensamblarse sobre una base sólida (como el hormigón o el asfalto).

- **Etapas CIMENTOS** : la cantidad total de hormigón que debe verterse es de 0,4 m3.
- **Etapas 15, 22 y 23** : apriete las tuercas para mantener los travesaños en su posición.
- **Etapas 18** : Se necesitan 4 personas para levantar el techo y poner los pies "J-150910".
- **Etapas 20 y 24** : retire los films de protección y luego aplique cinta adhesiva en los laterales de las placas de policarbonato.
- **Etapas 20 y 24** : instale el lado tratado con protección ultravioleta de los paneles de policarbonato hacia arriba. El lado con tratamiento contra los rayos ultravioleta está protegido por un film con inscripciones.
- **Etapas 22** : Se necesitan 4 personas para configurar y reparar los travesaños "J-150919".
- **Etapas ANCLAJE** : Antes del anclaje del producto debe comprobarse que los pies estén perfectamente nivelados
- **Etapas ANCLAJE** : para fijar el producto al suelo, hace falta:
 - realizar unos orificios de Ø8 en el hormigón para colocar los orificios de los pies de fijación del producto;
 - clavar con un martillo las espigas de anclaje «J-121374» en los orificios;
 - atornillar las espigas de anclaje.

MANTENIMIENTO

- Este producto no es un armazón, no se suba al techo.
- Conserve el techo y los canalones en perfecto estado de limpieza (nieve, suciedad, hojas). Una gran cantidad de nieve en el techo puede dañar el producto y hacerlo peligroso.
- Limpie el producto con agua limpia o con productos con PH neutro, especialmente en el caso de los paneles del techo
- Color de la pintura RAL: 7016
- Compruebe regularmente que los tornillos del producto están bien apretados.

Servicio posventa

- El servicio posventa solamente reemplaza las piezas faltantes y/o defectuosa, pero en ningún caso cambiará la totalidad del artículo.
- En función de la duración de la garantía de las piezas y del periodo transcurrido desde la compra del producto, se solicita al comprador que pague un porcentaje del precio de coste de las piezas indicado en la tabla siguiente.

Porcentaje de coste asumido por la empresa	Porcentaje de coste asumido por el cliente
100%	Sustitución gratuita de la pieza
60%	40%
50%	50%
40%	60%
30%	70%
20%	80%
10%	90%

- Las piezas que pudiesen faltar en el paquete inicial se proporcionarán de forma gratuita siempre y cuando la reclamación se lleve a cabo durante dos meses siguiente a la compra del producto.
- No se admiten demandas de indemnización (sea cual sea su forma).
- No se admitirá ninguna devolución de mercancía, salvo conformidad y solicitud expresa por nuestra parte.
- Cualquier producto defectuoso deberá mantenerse a disposición durante un mes, ya que podrá ser objeto de un examen técnico por nuestra parte.
- No puede modificarse el producto original (añadiendo un accesorio, por ejemplo). Solo deben utilizarse piezas de repuesto TRIGANO JARDIN. Escriba a la siguiente dirección para ponerse en contacto con el servicio posventa: <http://sav.triganojardin.com>

GARANTÍA

Para poderse beneficiar de la garantía, conserve este manual y un justificante de compra. Si tiene problemas con el producto, visite nuestro sitio web <http://sav.triganojardin.com>.

1. Condiciones:

- La garantía cubre un defecto de fabricación o el mal funcionamiento del producto en el contexto de su uso normal.
- Las garantías solamente serán válidas si el producto se instala, se utiliza y se mantiene de conformidad con las instrucciones especificadas en este manual.
- Cualquier manipulación incorrecta y cualquier modificación del producto más allá de las previstas en el manual, anulan todas las garantías.
- Las garantías no cubren los desperfectos provocados por unas condiciones climatológicas adversas (tormenta, granizo, inundación...) o cualquier otro caso de fuerza mayor (incendio, vandalismo...).

2. Exclusiones

- Montaje, instalación o uso incorrectos y/o falta de mantenimiento.
- Orificios, microperforaciones o desgarros accidentales como consecuencia del montaje o la utilización.
- Incumplimiento de las recomendaciones y las consignas indicadas en el manual de montaje y en la carta de recomendaciones.
- Incumplimiento de las consignas de precintado del producto antes del uso.
- Modificaciones en el producto, así como cualquier deterioro provocado por las condiciones meteorológicas adversas (lluvia, nieve, granizo, viento).

3. Duración:

- Las piezas de aluminio tienen una garantía de 15 años decrecientes, según la tabla siguiente.
- Las placas de policarbonato tienen una garantía de 10 años decrecientes, según la tabla siguiente.
- Las piezas de unión de acero tienen una garantía de 2 años, según la tabla siguiente.

Duración de la garantía	Años desde la compra del producto													
	2	3	4	5	6	7	8	9	10	11	12	13	14	15
2 años	100 %													
10 años	100 %	50 %	30 %	30 %	20 %	20 %	20 %	20 %	10 %					
15 años	100 %	60 %	50 %	50 %	40 %	40 %	30 %	30 %	20 %	20 %	20 %	10 %	10 %	10 %

Gentile Signora, Egregio Signore,

Grazie e congratulazioni per l'acquisto di questo prodotto progettato e realizzato da TRIGANO JARDIN. Per garantire un utilizzo efficace e sicuro, vi chiediamo di prestare la massima attenzione ai vari consigli forniti e di consultare le figure corrispondenti a ogni fase dell'installazione riportate nelle pagine seguenti. Conservare con cura le presenti istruzioni di montaggio in quanto potranno rivelarsi utili in futuro.

Grazie e cordiali saluti,

La Società TRIGANO JARDIN,

Michel ESNAULT - Direttore Generale.

IMPORTANTE

- Prima di procedere all'assemblaggio leggere attentamente le presenti istruzioni.
- Seguire scrupolosamente i vari passaggi nell'ordine indicato.
- Conservare le istruzioni per tutta la durata utile del prodotto.
- Massima resistenza al vento: 90 km/h
- Massima resistenza alla neve: 10 cm

SICUREZZA

- Prima di iniziare il montaggio verificare la presenza di tutti i pezzi dichiarati nella lista.
- Per ragioni di sicurezza, questo prodotto deve essere montato da almeno quattro persone.
- Alcuni pezzi hanno bordi taglienti. Fare attenzione durante la manipolazione e indossare guanti adeguati.
- Non tentare di assemblare il prodotto in giornate di vento o di pioggia.
- Conservare tutti i sacchetti di plastica fuori dalla portata dei bambini.
- Tenere i bambini lontani dalla zona di assemblaggio.
- Evitare di assemblare il prodotto se le condizioni fisiche non lo consentono (stanchezza, cure mediche, assunzione di alcol o se soggetti a svenimenti).
- Se si utilizzano scale o utensili elettrici rispettare le istruzioni dei relativi produttori.
- Non aggrapparsi o reggersi alla struttura della tettoia.
- Questo prodotto è stato progettato per essere utilizzato esclusivamente come riparo per un'automobile.
- Stringere nuovamente tutte le viti a fine montaggio.

INSTALLAZIONE

- Prendere contatto con l'amministrazione locale per verificare se l'installazione del prodotto richiede autorizzazioni specifiche.
- Questo articolo deve essere installato facendo particolare attenzione alla planarità del terreno, in quanto sussiste il rischio di squilibrio o di rovesciamento.
- Il prodotto deve obbligatoriamente essere ancorato al suolo, al fine di assicurarne la stabilità e la rigidità, oltre a renderne valida la garanzia.
- Durante l'assemblaggio, posare i pezzi su elementi morbidi come il cartone da imballaggio, così da evitare il rischio di graffi e danni.
- Scegliere una collocazione al riparo dai venti dominanti e da potenziali accumuli di neve (ad esempio in prossimità di tetti, alberi, ecc.)

Il prodotto dovrà essere assemblato su una base solida (come cemento o asfalto).

- **Fase FONDAMENTA** : La quantità complessiva di cemento da versare è di 0,4m³.
- **Fasi 15, 22 e 23** : Serrare i dadi per mantenere le traverse in posizione.
- **Fase 18** : Devi essere 4 persone per sollevare il tetto e mettere i piedi "J-150910".
- **Fasi 20 e 24** : Rimuovere le pellicole di protezione e applicare del nastro adesivo sui lati aperti del policarbonato.
- **Fasi 20 e 24** : Installare i pannelli di policarbonato con la superficie trattata anti-UV rivolta verso l'alto. Il lato trattato anti-UV è protetto da una pellicola che riporta le relative diciture.
- **Fase 22** : Devi essere 4 persone per installare e riparare le traverse "J-150919".
- **Fasi ANCORAGGIO** : Prima dell'ancoraggio del prodotto, controllare l'angolo di posizionamento dei piedi utilizzando una livella
- **Fasi ANCORAGGIO** : Per fissare il prodotto al suolo occorre:
 - Praticare dei fori di Ø8 nel cemento in corrispondenza dei fori dei piedi di fissaggio del prodotto;
 - Inserire con un martello i perni di ancoraggio "J-121374" nei fori;
 - Avvitare i perni di ancoraggio.

MANUTENZIONE

- Questo prodotto non è dotato di una struttura portante, non salire sopra la tettoia.
- Pulire regolarmente e accuratamente il tetto e le grondaie (neve, sporcizia, foglie). Qualora vi si depositasse una grossa quantità di neve, la tettoia potrebbe subire danni e diventare pericolosa.
- Pulire il prodotto con acqua di rubinetto o con prodotti a pH neutro specifici per i pannelli delle tettoie
- Colore della vernice RAL: 7016
- Verificare regolarmente il serraggio delle viti del prodotto.

•SERVIZIO POST VENDITA

- Il servizio post vendita è autorizzato a sostituire esclusivamente i componenti mancanti e/o difettosi e in alcun caso procederà alla sostituzione della totalità dell'articolo.
- A seconda della durata della garanzia dei pezzi e del periodo trascorso dall'acquisto del prodotto, verrà richiesto all'acquirente di corrispondere una percentuale del costo dei pezzi in base alla tabella riportata di seguito.

Percentuale sostenuta dall'azienda	Percentuale sostenuta dal cliente
100%	Sostituzione gratuita del pezzo
60%	40%
50%	50%
40%	60%
30%	70%
20%	80%
10%	90%

- Eventuali pezzi mancanti nell'imballaggio iniziale saranno forniti gratuitamente a condizione che il reclamo sia presentato entro due mesi dall'acquisto.
- Qualsiasi richiesta di risarcimento, a prescindere dal motivo e dalla natura, non sarà presa in considerazione.
- La merce non potrà essere in alcun caso restituita, salvo previo consenso esplicito o richiesta specifica da parte dell'azienda.
- Qualsiasi prodotto difettoso dovrà essere conservato e tenuto a disposizione per un mese, al fine di consentire la perizia da parte dell'azienda.
- Non è possibile modificare il prodotto originale (per esempio, aggiungendo un accessorio). Devono essere utilizzati solo pezzi di ricambio TRIGANO JARDIN. Per qualsiasi ulteriore richiesta di servizio post vendita, si prega di visitare il seguente sito: <http://sav.triganojardin.com>

GARANZIA

Per usufruire della garanzia, conservare le presenti istruzioni e la ricevuta di acquisto.

In caso di problemi riscontrati sul prodotto, consultare il nostro sito Internet <http://sav.triganojardin.com>.

1. Condizioni:

- La garanzia copre difetti di fabbricazione o cattivo funzionamento del prodotto nel quadro di un utilizzo normale.
- Le garanzie saranno ritenute valide solo se il prodotto sarà stato installato, utilizzato e mantenuto conformemente alle presenti istruzioni.
- Qualsiasi errata manipolazione e qualsiasi modifica del prodotto non conforme a quanto previsto nelle istruzioni provoca l'annullamento della garanzia.
- Le garanzie non coprono i danni causati dalle intemperie (tempesta, grandine, inondazione, ecc.) o da qualsiasi altro evento di forza maggiore (incendio, atto vandalico, ecc.).

2. Esclusioni

- Montaggio errato, installazione o utilizzo scorretti e/o manutenzione insufficiente.
- Fori, micro perforazioni o strappi accidentali causati dal montaggio o dall'utilizzo.
- Mancato rispetto di raccomandazioni e istruzioni riportate nel manuale di montaggio e nella lettera di raccomandazioni.
- Mancato rispetto delle istruzioni di sigillatura del prodotto prima dell'uso.
- Modifiche ai prodotti e deterioramenti dovuti alle intemperie (pioggia, neve, grandine, vento).

3. Durata:

- I pezzi in alluminio sono garantiti 15 anni regressivi secondo la tabella riportata di seguito.
- Le piastre in policarbonato sono garantite 10 anni regressivi secondo la tabella riportata di seguito.
- I pezzi di giunzione in acciaio sono garantiti 2 anni regressivi secondo la tabella riportata di seguito.

Durata della garanzia	Anni a partire dall'acquisto del prodotto														
	2	3	4	5	6	7	8	9	10	11	12	13	14	15	
2 anni	100 %														
10 anni	100 %	50 %	30 %	30 %	20 %	20 %	20 %	20 %	10 %						
15 anni	100 %	60 %	50 %	50 %	40 %	40 %	30 %	30 %	20 %	20 %	20 %	10 %	10 %	10 %	

Geachte klant,

Wij willen u graag feliciteren en bedanken voor de aanschaf van dit product dat is ontworpen en geproduceerd door TRIGANO JARDIN. Wij vragen u om de verschillende tips hieronder aandachtig door te lezen en de bijbehorende tekeningen op de volgende pagina's goed te bekijken, zodat het toestel onder zo veilig mogelijke omstandigheden kan worden gebruikt. Bewaar deze montagehandleiding zorgvuldig voor eventueel toekomstig gebruik.

Met vriendelijke groet,

TRIGANO JARDIN,

Michel ESNAULT - Algemeen Directeur.

BELANGRIJK

- Lees de instructies zorgvuldig door voordat u het product monteert.
- Volg de verschillende stappen nauwkeurig en in de juiste volgorde op.
- Bewaar de instructies gedurende de volledige levensduur van het product.
- Maximale windbestendigheid: 90 km/uur.
- Maximale sneeuwbestendigheid: 10 cm.

VEILIGHEIDSADVIEZEN

- Sorteer de onderdelen en controleer de onderdelenlijst voordat u met de montage begint.
- Om veiligheidsredenen moet dit product door minstens vier personen worden gemonteerd.
- Sommige onderdelen hebben ruwe randen. Hanteer de onderdelen voorzichtig en draag altijd handschoenen tijdens het monteren.
- Probeer het product niet te monteren wanneer het waait of regent.
- Houd alle plastic zakken buiten het bereik van kinderen.
- Houd kinderen uit de buurt van de werkplaats waar u het product monteert.
- Monteer het product niet als u moe bent, medicijnen gebruikt, onder invloed van alcohol bent of als u zich duizelig voelt.
- Als u een ladder of elektrisch gereedschap gebruikt, volg dan de veiligheidsinstructies van de fabrikant op.
- Klim niet op het dak en ga er niet op staan.
- Dit product is uitsluitend ontworpen en geproduceerd om te worden gebruikt als een carport.
- Draai alle schroeven aan het einde van de montage goed vast.

INSTALLATIE

- Neem contact op met de plaatselijke autoriteiten om na te gaan of er vergunningen nodig zijn om het product te mogen installeren.
 - Dit artikel moet zorgvuldig worden geïnstalleerd op een vlakke en horizontale ondergrond, anders staat het niet in balans en/of kan het omvallen.
 - De verankering van het product in de grond is verplicht om de stabiliteit en weerstand van het product te kunnen waarborgen, en om van de garantie gebruik te kunnen maken.
 - Leg tijdens de montage soepele elementen, zoals de kartonnen verpakking, onder de onderdelen om krassen en beschadiging te voorkomen.
 - Kies een locatie die beschut is tegen windvlagen en vrij is van zones waar sneeuw zich kan ophopen (zoals een dak, bomen enz.).
- Dit product moet op een solide ondergrond (zoals beton of asfalt) worden gemonteerd.
- **FUNDERING** : De totale hoeveelheid te storten beton bedraagt 0,4 m³.
 - **Stappen 15, 22 en 23**: Draai de moeren aan om de dwarsbalken in positie te houden.
 - **Stap 18** : Je moet met 4 personen zijn om het dak op te tillen en de voeten "J-150910" te plaatsen.
 - **Stappen 20 en 24** : Verwijder de beschermfolie en breng plakband aan op de open zijden van het polycarbonaat.
 - **Stappen 20 en 24** : Installeer de polycarbonaatplaten met de uv-behandelde zijde naar boven. De uv-behandelde zijde herkent u aan de beschermfolie met inscripties.
 - **Stap 22** : Je moet 4 personen zijn om de dwarsbalken "J-150919" op te zetten en te bevestigen.
 - **VERANKERING** : Door het verankeren van het product, kijk met behulp van een waterpas, de hoek van de poten na.
 - **VERANKERING** : Om het product in de grond te verankeren, moet u het volgende doen:
 - Boor gaten van Ø8 in het beton op de plaats van de gaten in de bevestigingspoten van het product.
 - Sla de J-121374-ankerbouten in de gaten.
 - Schroef de ankerbouten vast.

ONDERHOUD

- Dit product is geen draagconstructie, klim niet op het dak.
- Houd het dak en de dakgoten perfect schoon (geen sneeuw, vuil of bladeren). Een grote hoeveelheid sneeuw op het dak kan het product beschadigen en gevaarlijk maken.
- Reinig het product met helder water of met producten met een neutrale pH-waarde, meer bepaald de dakpanelen.
- RAL-verfkleur: 7016.
- Controleer regelmatig of de schroeven van het product goed vastzitten.

Klantenservice

- De klantenservice vervangt alleen ontbrekende en/of defecte onderdelen, maar in geen geval het volledige artikel.
- Afhankelijk van de garantieperiode van de onderdelen en de periode die sinds de aankoop van het product is verstreken, is de koper verplicht een percentage van de kostprijs van de onderdelen volgens onderstaande tabel te betalen.

Percentage van de kosten voor rekening van de onderneming	Percentage van de kosten voor rekening van de klant
100%	Gratis vervanging van het onderdeel
60%	40%
50%	50%
40%	60%
30%	70%
20%	80%
10%	90%

- Eventuele ontbrekende onderdelen in de oorspronkelijke verpakking worden gratis ter beschikking gesteld, mits de claim binnen twee maanden na aankoop van het product wordt ingediend.
- Vorderingen tot schadevergoeding (in welke vorm dan ook) worden niet aanvaard.
- Geen enkele terugzending van goederen wordt aanvaard, tenzij uitdrukkelijk overeengekomen en door ons aangevraagd.
- Defecte producten moeten gedurende 1 maand ter beschikking worden gehouden, want zij kunnen door ons worden teruggenomen voor een deskundig onderzoek.
- Het is niet mogelijk om het oorspronkelijke product te wijzigen (bijvoorbeeld door een accessoire toe te voegen). Gebruik alleen originele reserveonderdelen van TRIGANO JARDIN. Neem voor vragen na de aankoop contact op met de klantenservice via het volgende adres: <http://sav.triganojardin.com>

GARANTIE

Bewaar deze handleiding en het aankoopbewijs om van uw garantie gebruik te kunnen maken.

Bezoek in geval van problemen met uw product onze website <http://sav.triganojardin.com>.

1. Voorwaarden:

- De garantie dekt een fabricagefout of het niet-functioneren van het product bij normaal gebruik.
- Garanties zijn alleen geldig als het product wordt geïnstalleerd, gebruikt en onderhouden in overeenstemming met de instructies in de handleiding.
- Onjuiste hantering en wijzigingen van het product die niet zijn voorzien in de handleiding maken de garantie ongeldig.
- De garantie dekt geen schade veroorzaakt door slecht weer (storm, hagel, overstroming enz.) of enig ander geval van overmacht (brand, vandalisme enz.).

2. Uitsluitingen:

- Onjuiste montage, installatie, gebruik en/of onderhoud.
- Gaten, microperforaties of onbedoelde scheuren als gevolg van montage of gebruik.
- Het niet naleven van de adviezen en instructies in de montagehandleiding en de brief met adviezen.
- Het niet naleven van de instructies voor het vastzetten van het product vóór gebruik.
- Wijzigingen aan producten en schade door slecht weer (regen, sneeuw, hagel, wind).

3. Duur:

- Aluminium onderdelen hebben een degressieve garantie van 15 jaar volgens onderstaande tabel.
- Polycarbonaatplaten hebben een degressieve garantie van 10 jaar volgens onderstaande tabel.
- Stalen verbindingsonderdelen hebben een garantie van 2 jaar volgens onderstaande tabel.

Warranty period	Number of years since the product purchase date														
	2	3	4	5	6	7	8	9	10	11	12	13	14	15	
2 years	100 %														
10 years	100 %	50 %	30 %	30 %	20 %	20 %	20 %	20 %	10 %						
15 years	100 %	60 %	50 %	50 %	40 %	40 %	30 %	30 %	20 %	20 %	20 %	10 %	10 %	10 %	

Caro(a) Sr.(a),

Gostaríamos de o(a) felicitar e agradecer por ter comprado este produto que foi concebido e fabricado pela TRIGANO JARDIN. Para que possa ser utilizado nas melhores condições possíveis de segurança, pedimos-lhe que preste a devida atenção aos diferentes conselhos mencionados a seguir e que consulte as imagens correspondentes que se encontram nas páginas seguintes. Guarde cuidadosamente este manual de montagem que poderá ser-lhe útil no futuro.

Com os nossos melhores cumprimentos,

Empresa TRIGANO JARDIN,

Michel Esnault - diretor-geral.

IMPORTANTE

- Leia com atenção as instruções antes de realizar a montagem do produto.
- Siga as diferentes etapas cuidadosamente e na ordem indicada.
- Guarde as instruções durante a vida útil do produto.
- Resistência máxima ao vento: 90 km/h
- Resistência máxima à neve: 10 cm

SEGURANÇA

- Separe as peças e verifique a lista do conteúdo antes de realizar a montagem.
- Por razões de segurança, este produto deve ser montado, no mínimo, por quatro pessoas.
- Algumas peças têm arestas afiadas. Tenha cuidado durante a utilização e use sempre luvas durante a montagem.
- Não tente montar o produto em condições de vento ou chuva.
- Mantenha todos os sacos de plástico fora do alcance das crianças.
- As crianças devem estar afastadas da área de montagem.
- Evite montar o produto se estiver cansado, a tomar medicamentos, sob o efeito de álcool ou com tonturas.
- Se utilizar uma escada ou ferramentas elétricas, siga as recomendações de segurança do fabricante.
- Não trepe ou se agarre ao telhado.
- Este produto foi concebido e fabricado para ser utilizado apenas como resguardo para automóveis.
- Aperte todos os parafusos no final da montagem.

INSTALAÇÃO

- Consulte as autoridades locais para verificar se é necessária uma licença para instalar o produto.
- Este produto deve ser montado cuidadosamente numa superfície plana e horizontal, caso contrário poderá tornar-se instável ou cair.
- A fixação do produto no chão é obrigatória para garantir a estabilidade e a rigidez do mesmo e assegurar a garantia.
- Durante a montagem, utilize elementos flexíveis como uma caixa de embalagem debaixo das peças para evitar riscos e danos.
- Escolha um local que não esteja exposto a ventos fortes e fontes de acumulação de neve (telhados, árvores, etc.).
- Este produto deve ser montado numa superfície sólida, como cimento ou asfalto.
- **Etapas FUNDAÇÃO** : a quantidade total de cimento a deitar é de 0,4 m³.
- **Etapas 15, 22 e 23** : Apertar os parafusos para manter as traves no lugar.
- **Etapas 18** : Você deve ter 4 pessoas para levantar o teto e colocar os pés "J-150910".
- **Etapas 20 e 24** : Retirar as películas de proteção e em seguida, aplicar fita adesiva nos flancos abertos do policarbonato.
- **Etapas 20 e 24** : Instale o lado tratado anti-UV dos painéis de policarbonato para o céu. O lado tratado anti-UV está protegido por uma película com inscrições.
- **Etapas 22** : Você deve ter 4 pessoas para instalar e consertar as travessas "J-150919".
- **Etapas FIXAÇÃO** : Verificar a esquadria dos pés com um nível de água antes de fixar o produto.
- **Etapas FIXAÇÃO** : Para fixar o produto no chão, é necessário:
 - Fazer furos com um diâmetro de 8 no cimento no local dos orifícios dos pés de fixação do produto;
 - Empurrar com um martelo os pinos de fixação "J-121374" nos orifícios;
 - Apertar os pinos de fixação.

MANUTENÇÃO

- Este produto não é uma estrutura. Não deve subir no telhado.
- Mantenha o telhado e os algerozes bem limpos, sem neve, sujidade e folhas. Uma grande quantidade de neve no telhado pode danificar o produto e torná-lo perigoso.
- Limpe o produto com água limpa ou produtos com PH neutro, principalmente os painéis do telhado.
- Cor da pintura RAL: 7016.
- Verifique regularmente o aperto dos parafusos do produto.

SPV

- O serviço pós-venda substitui apenas as peças em falta e/ou com defeito e em caso algum, todo o produto.
- De acordo com a duração da garantia das peças e o período a contar da data de compra do produto, o comprador deve pagar uma percentagem do preço de custo das peças de acordo com a seguinte tabela.

Percentagem assumida pela empresa	Percentagem assumida pelo cliente
100%	Substituição gratuita das peças
60%	40%
50%	50%
40%	60%
30%	70%
20%	80%
10%	90%

- As eventuais peças em falta na encomenda inicial são fornecidas gratuitamente desde que a reclamação seja efetuada no prazo de dois meses a contar da data de compra do produto.
- Os pedidos de indemnização (independentemente da forma) não são aceites.
- Não será aceite a devolução do produto, salvo acordo e pedido específico da nossa parte.
- O produto com defeito deve estar disponível durante um mês, uma vez que poderá ser objeto de uma retoma para efeitos de avaliação da nossa parte.
- Não é possível alterar o produto original (por exemplo, adicionar acessórios). Devem ser utilizadas apenas as peças sobresselentes da TRIGANO JARDIN. Para qualquer dúvida relacionada com o serviço pós-venda, aceda ao seguinte endereço: <http://sav.triganojardin.com>

Garantia

Para beneficiar da garantia, guarde este manual e o comprovativo de compra.

Em caso de problemas com o produto, aceda ao nosso website <http://sav.triganojardin.com>.

1. Condições:

- A garantia cobre defeitos de fabrico ou o não funcionamento do produto no âmbito de uma utilização normal.
- A garantia será válida apenas se o produto tiver sido instalado, utilizado e mantido em conformidade com as instruções mencionadas no manual.
- A má utilização e qualquer alteração do produto além das previstas no manual anulam a garantia.
- A garantia não cobre os danos causados por intempéries (tempestades, granizo, inundações, etc.) ou casos de força maior (incêndio, vandalismo, etc.).

2. Exclusões

- Montagem, instalação e utilização incorretas e/ou falta de manutenção.
- Furos, micro perfurações ou rasgos acidentais consecutivos à montagem ou utilização.
- Incumprimento das recomendações e instruções indicadas no manual de montagem e na carta de recomendações.
- Incumprimento das instruções de selagem do produto antes da utilização.
- Alterações no produto e danos causados por intempéries (chuva, neve, granizo e vento).

3. Duração:

- As peças em alumínio têm uma garantia de 15 anos regressivos de acordo com a seguinte tabela.
- As placas de policarbonato têm uma garantia de dez anos regressivos de acordo com a seguinte tabela.
- As juntas de aço têm uma garantia de dois anos de acordo com o quadro abaixo.

Duração da garantia	Número de anos a contar da data de compra do produto														
	2	3	4	5	6	7	8	9	10	11	12	13	14	15	
2 anos	100 %														
10 anos	100 %	50 %	30 %	30 %	20 %	20 %	20 %	20 %	10 %						
15 anos	100 %	60 %	50 %	50 %	40 %	40 %	30 %	30 %	20 %	20 %	20 %	10 %	10 %	10 %	

NOMENCLATURE

J-121518 Ø8
x214



J-121615 Ø8
x256



J-121616 Ø5
x76



J-121211 Ø8x50mm
x48



J-121116 Ø8x20mm
x124



J-121122 Ø8x90mm
x18

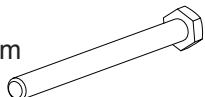

J-121125 Ø8x70mm
x24

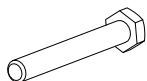

J-121341 Ø5x16mm
x76



J-121374 Ø8x95mm
x24



J-150910
x6

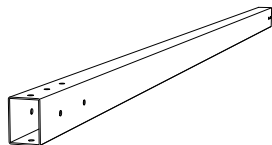

J-150921
x8

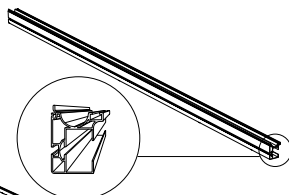

J-150922
x8

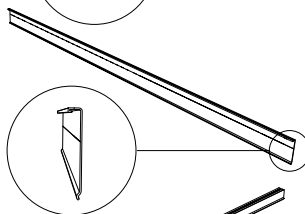

J-150919
x12

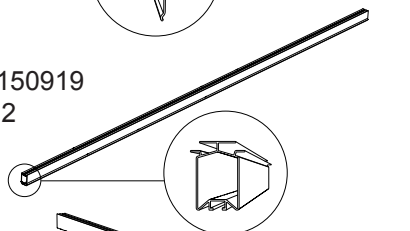

J-150920
x4



J-122596
x14

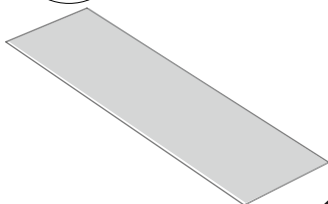

J-150901
x8

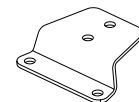

J-150902
x4

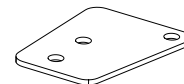

J-150903
x4

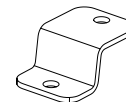

J-150900
x8

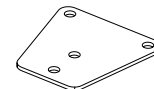

J-150904
x12

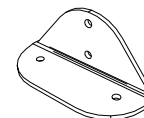

J-122594
x280



J-150905
x12

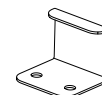

J-150906
x14

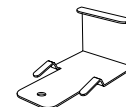

J-150930
x14

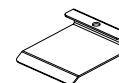

J-150911
x8

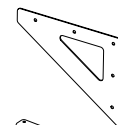

J-150925
x2



J-150913
x2

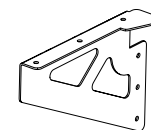

J-150912
x2

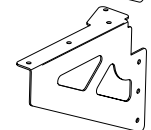

J-150926
x2

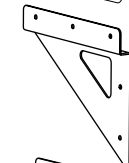

J-150927
x2

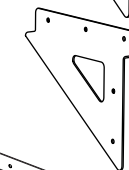

J-150923
x4

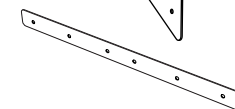

J-150909
x4

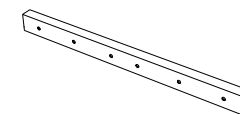

J-150908
x8

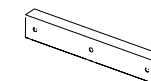

J-150924
x2



J-150918
x2

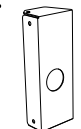

J-150917
x2

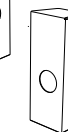

J-150907
x4



OUTILLAGES / TOOLS



VUE EN ECLATE / EXPLODED VIEW

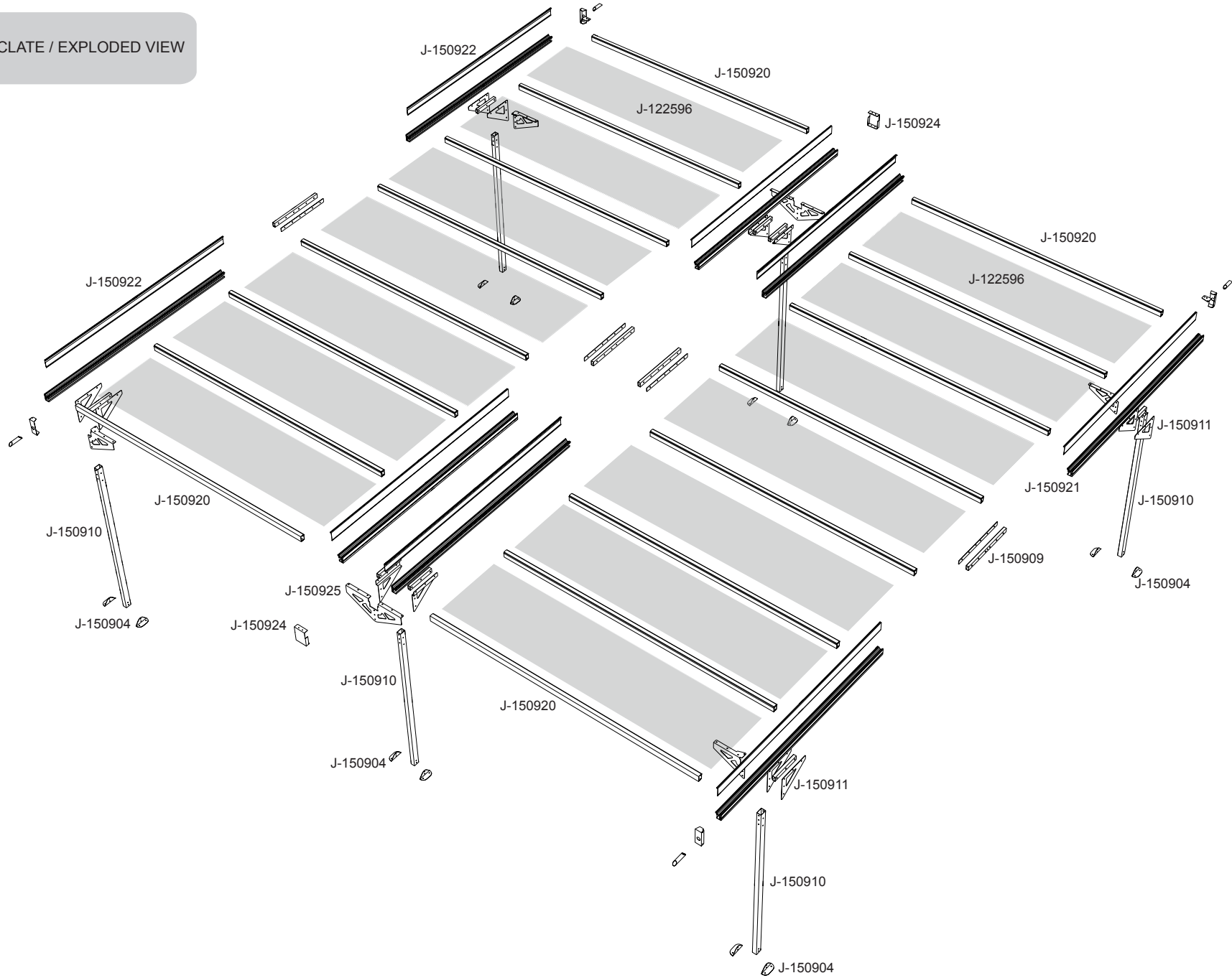

FONDATION

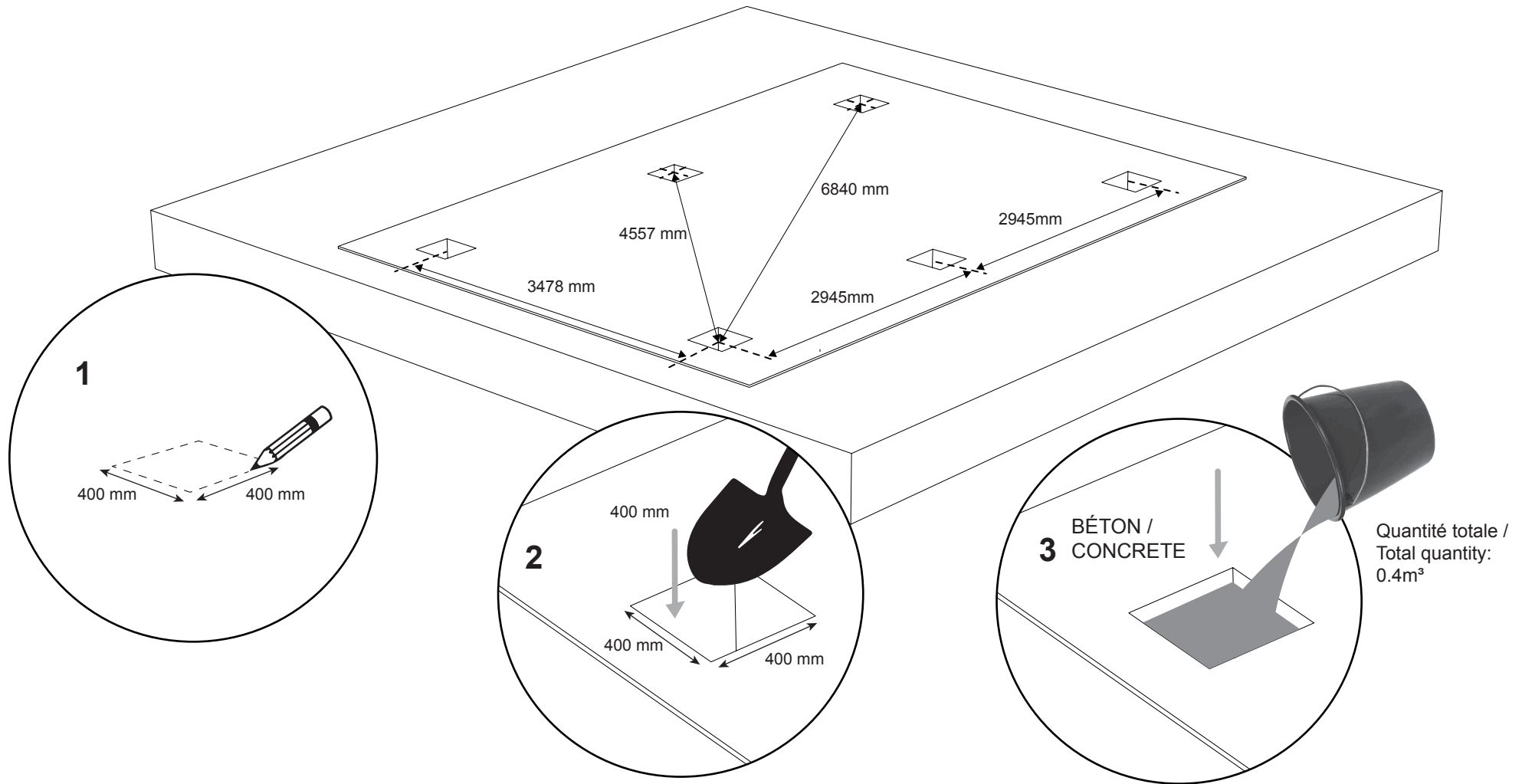

1

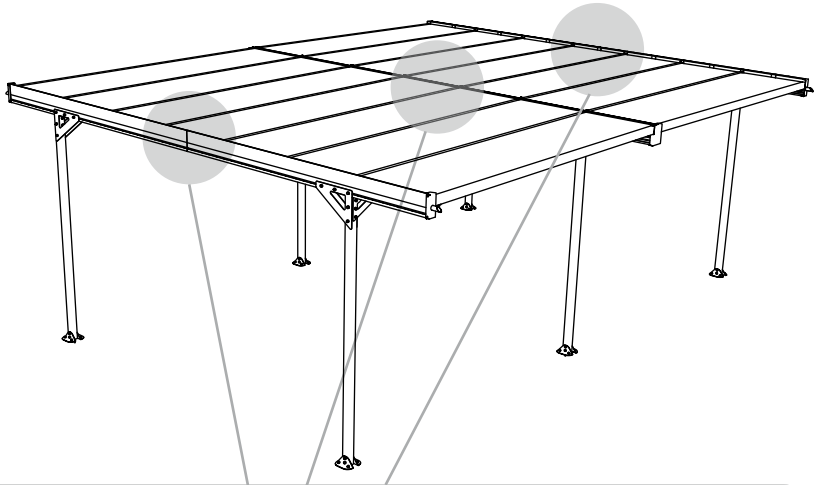
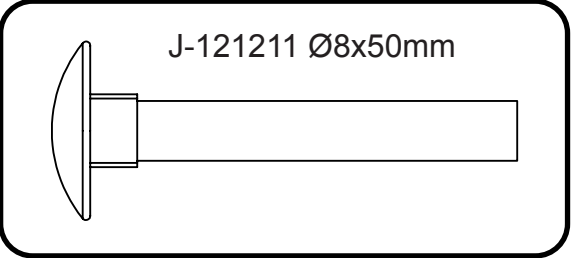

J-121518

J-121615 Ø8

J-121211

J-150923

J-150909



x24



x24



x24

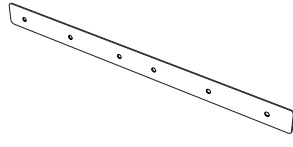

x4

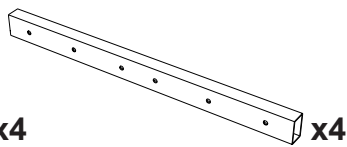

x4

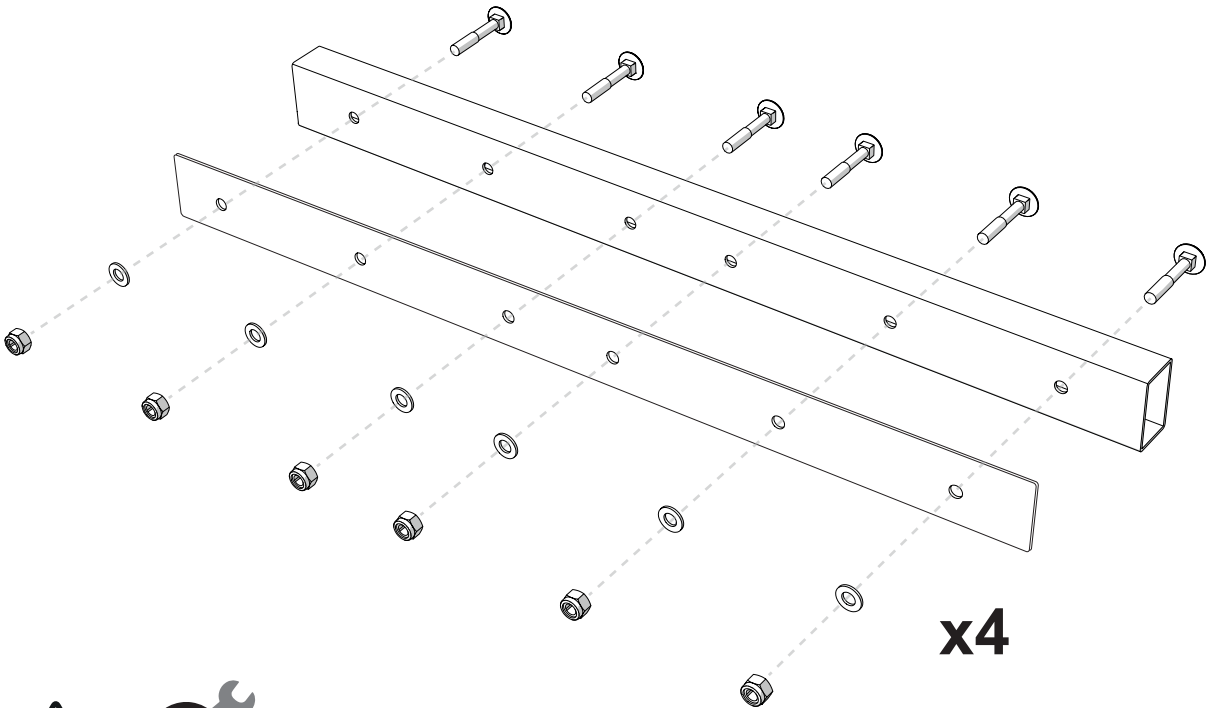

x4

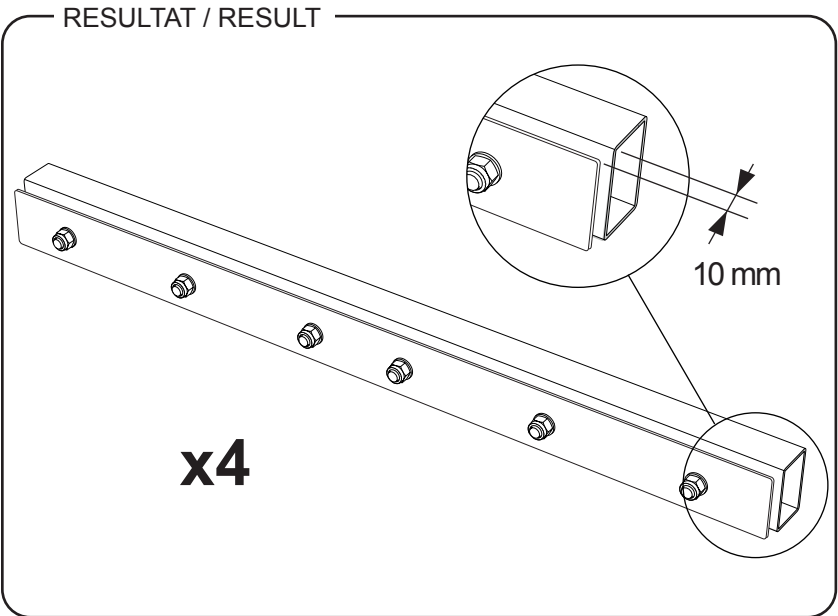

2

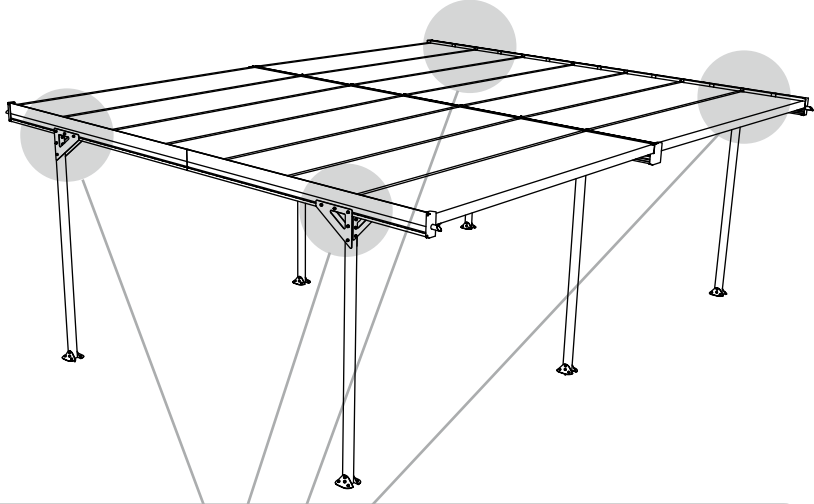
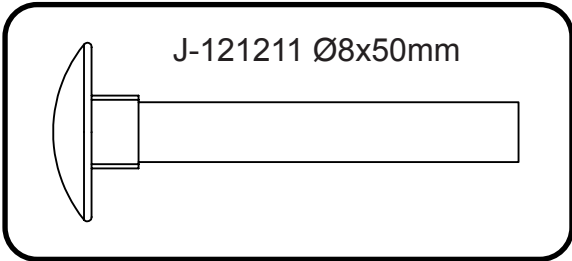

J-121518

J-121615 Ø8

J-121211

J-150908

J-150911

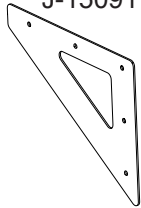
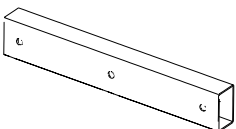

x12

x12

x12

x4

x4

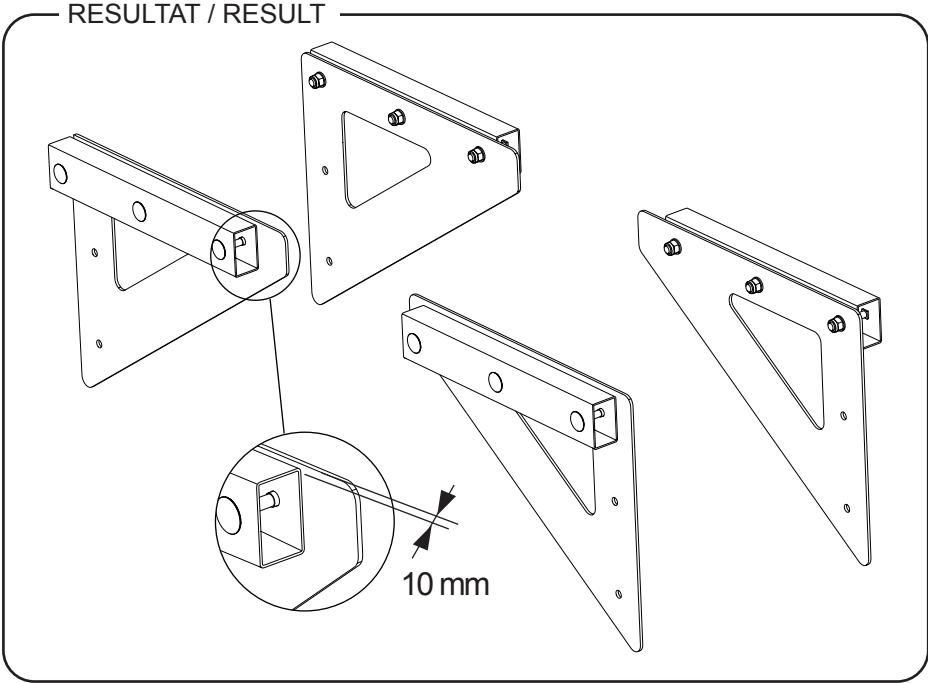
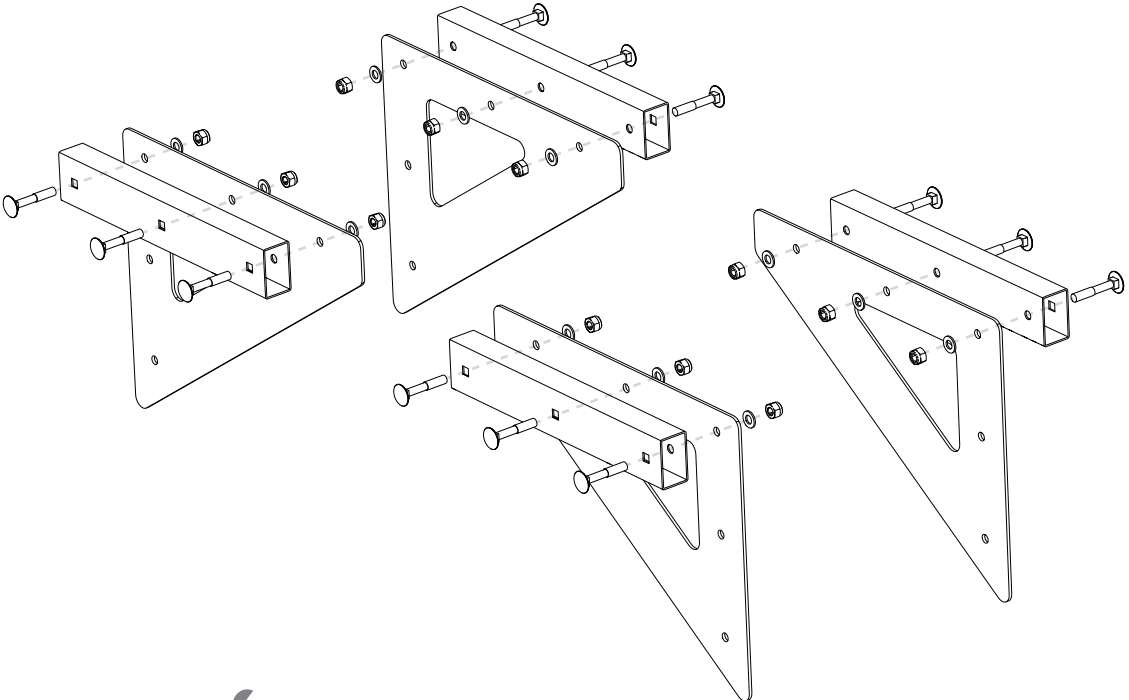

3

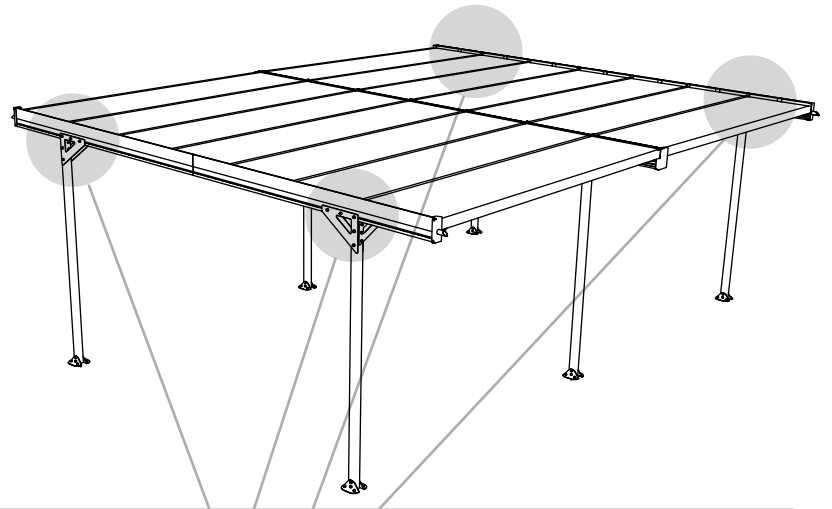
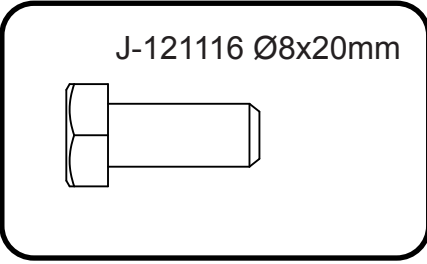
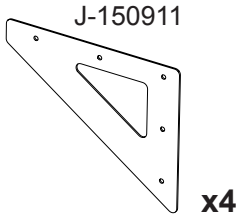

J-121518

J-121615 Ø8

J-121116

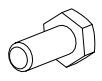

x12

x12

x12

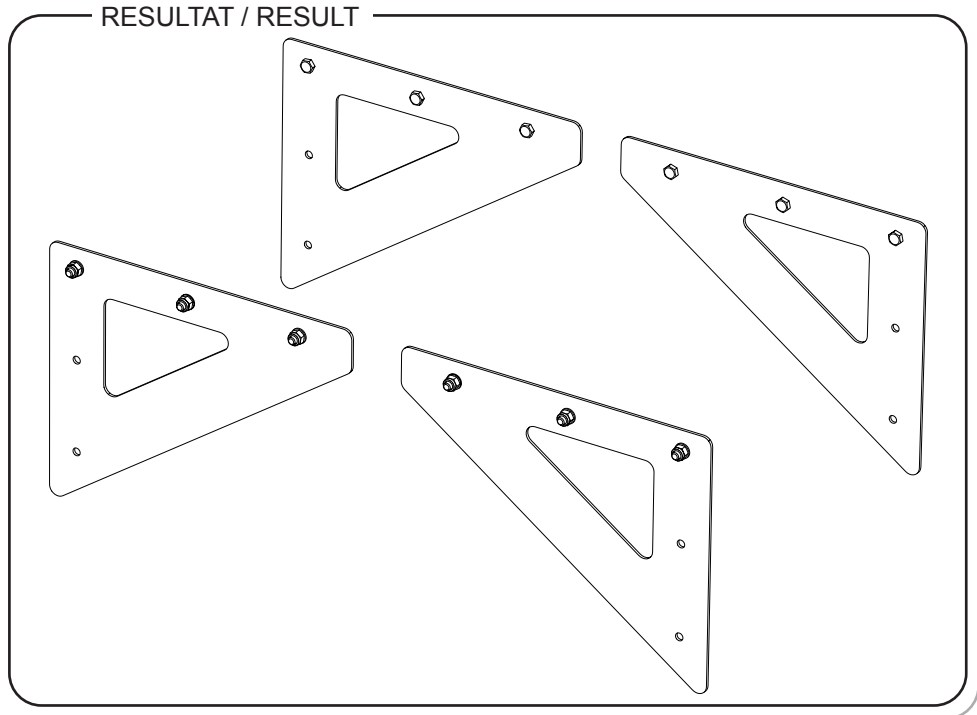
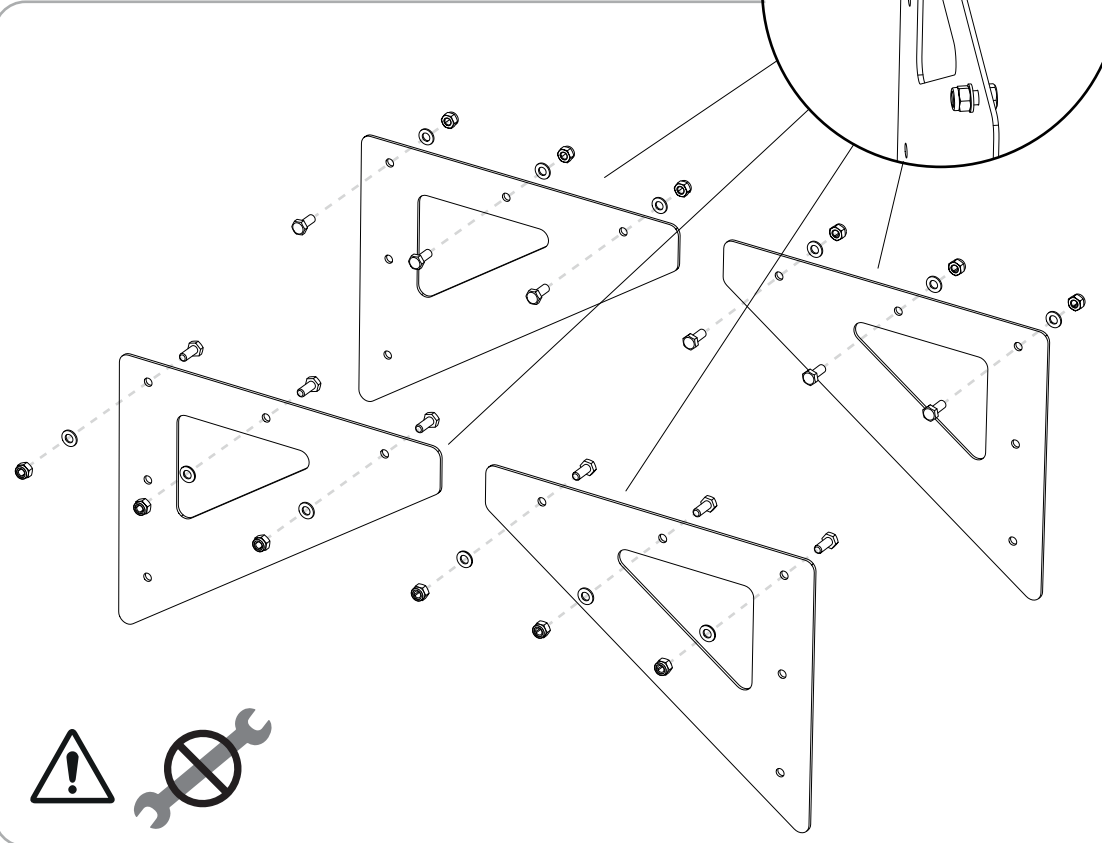
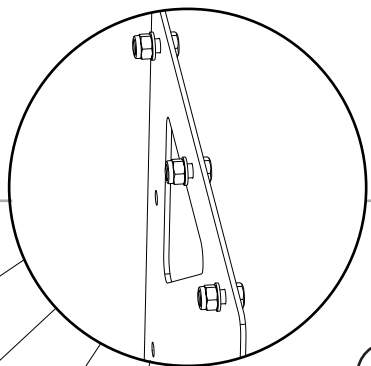

4

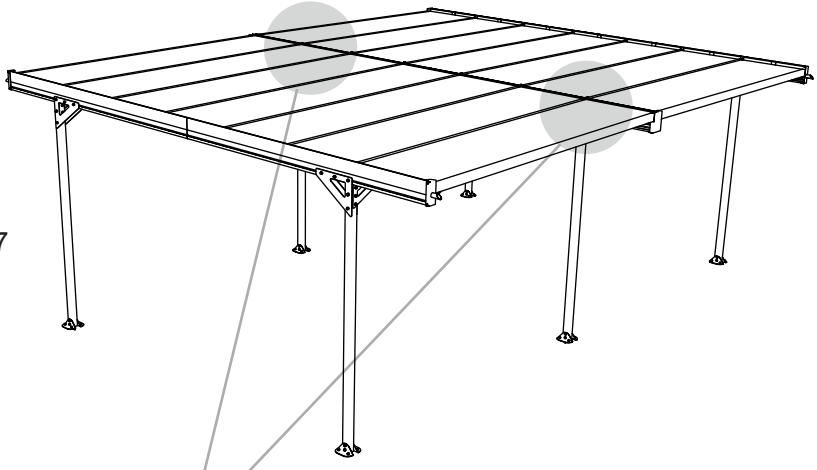
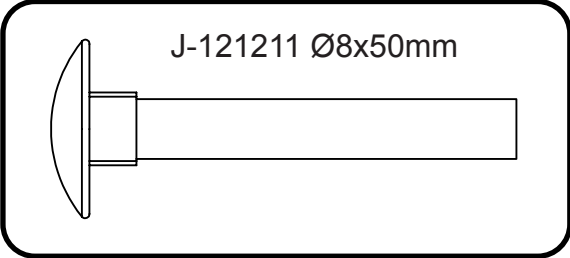

J-121518

J-121615 Ø8

J-121211

J-150908

J-150926

J-150927



x12



x12



x12

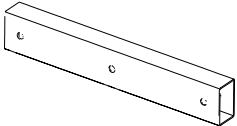

x4

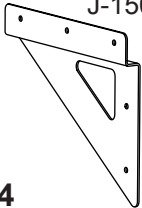

x2

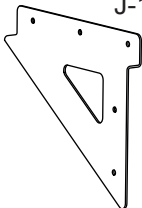

x2

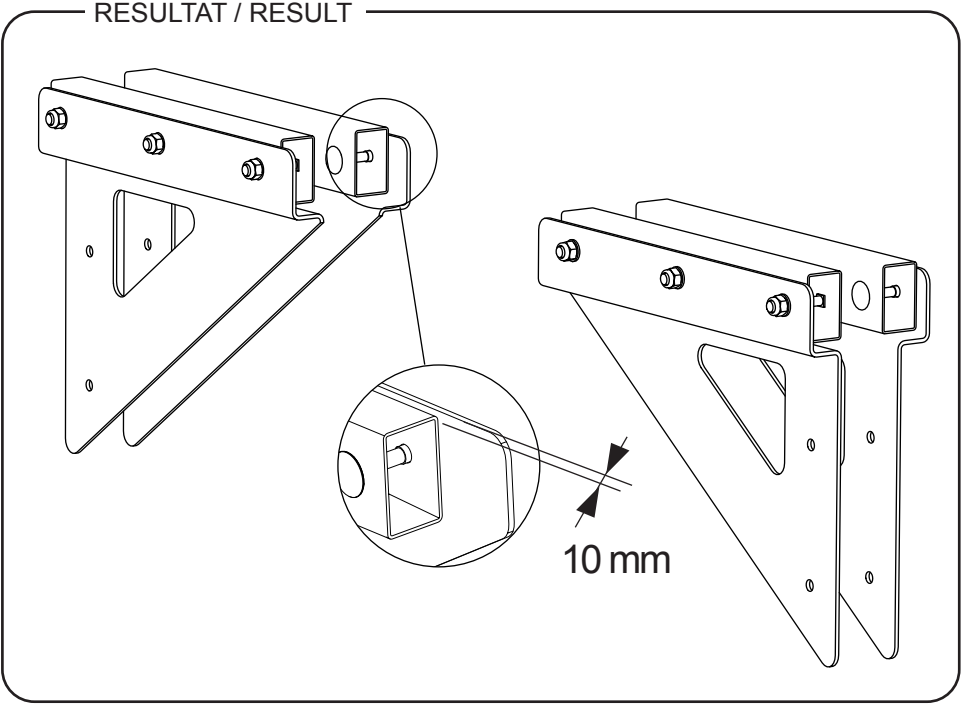
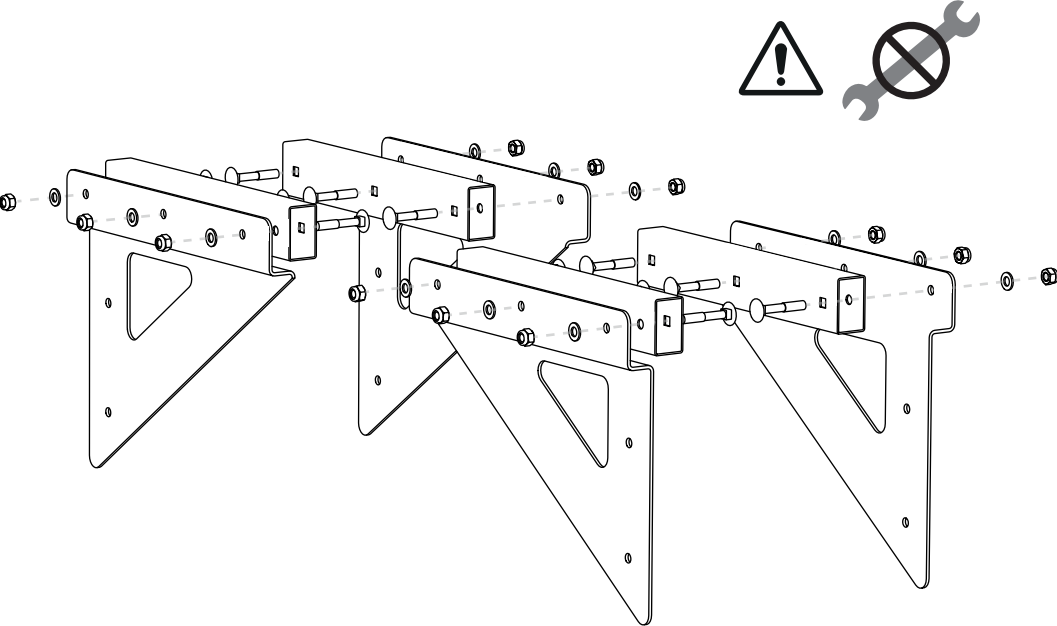

5

J-150913

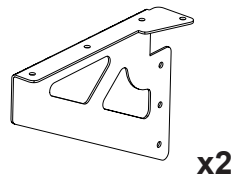

x2

J-150912

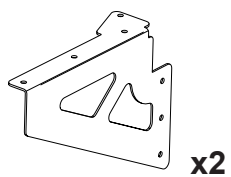

x2

J-121116 Ø8x20mm

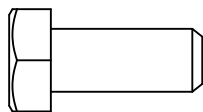

J-121518



x4

J-121615 Ø8



x4

J-121116



x4

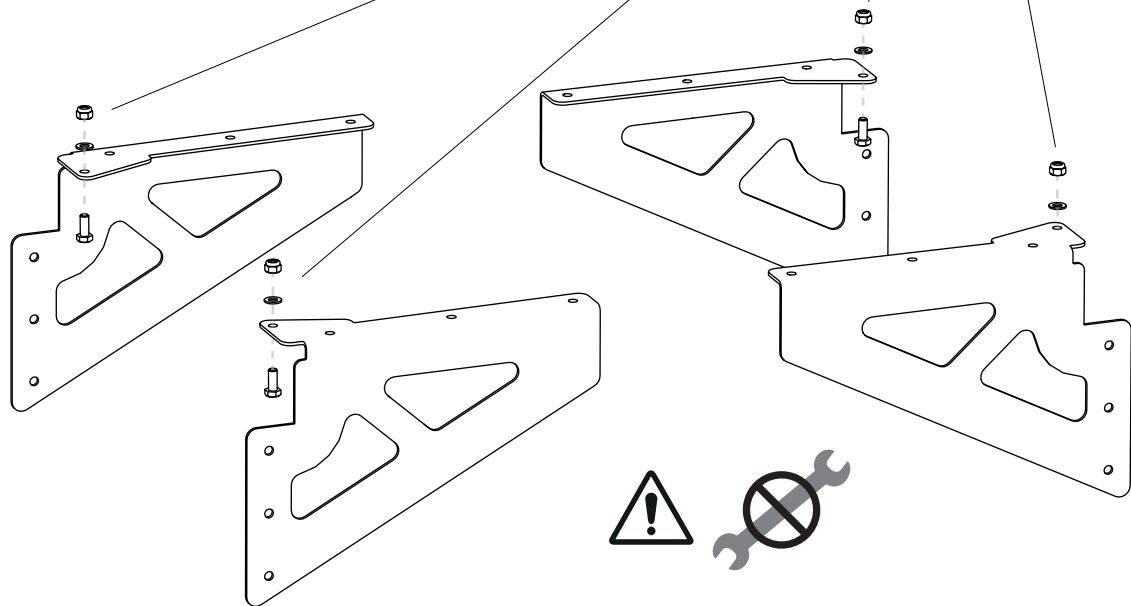
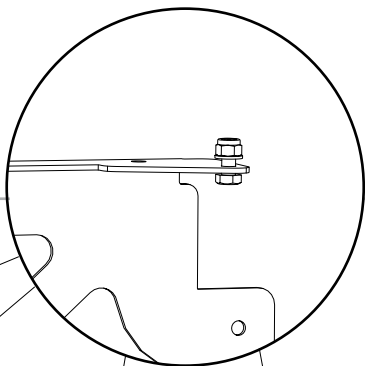
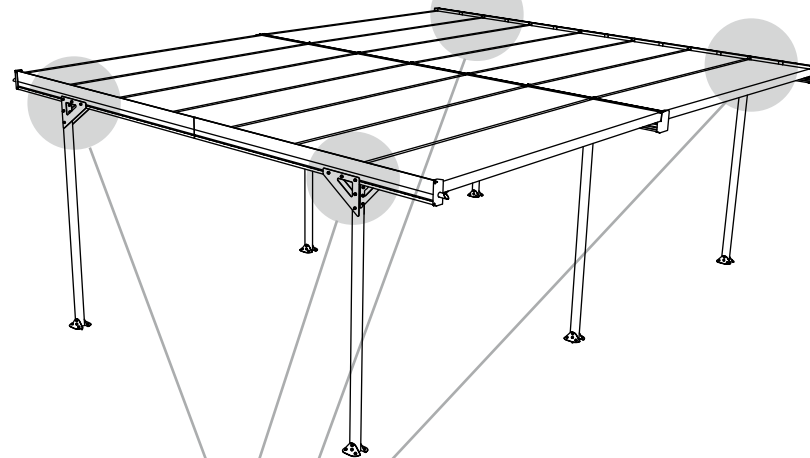

RESULTAT / RESULT

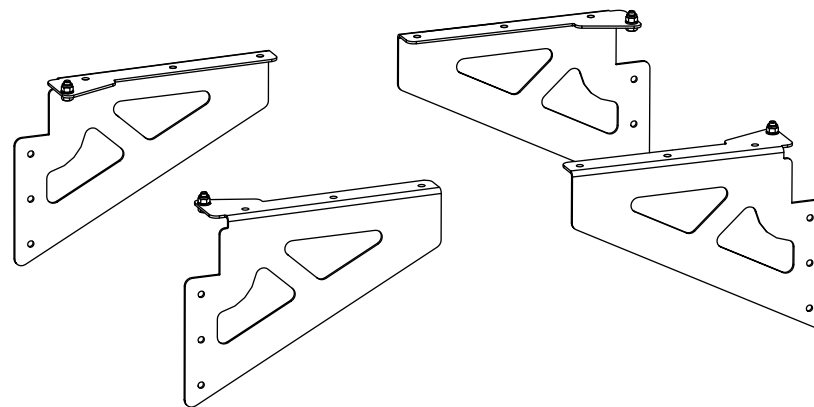

6

J-121116 Ø8x20mm

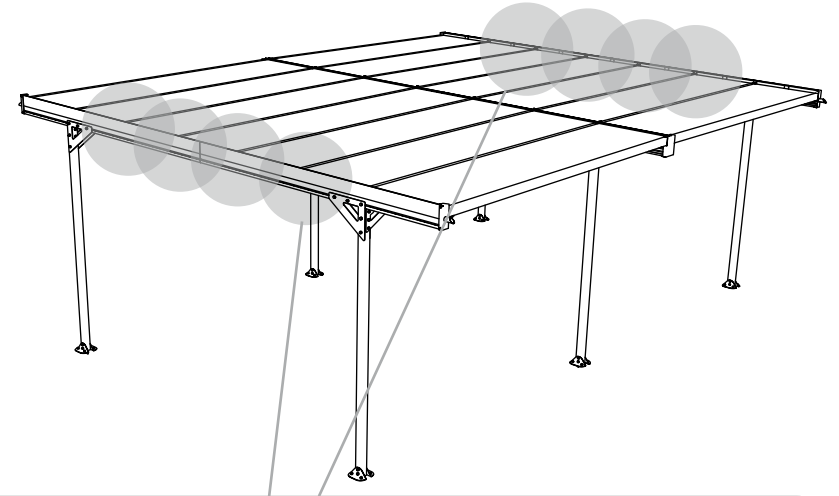
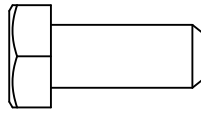

J-121518

J-121615 Ø8

J-121116

J-150900

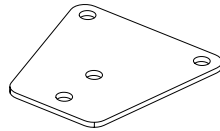

x16

x16

x16

x8

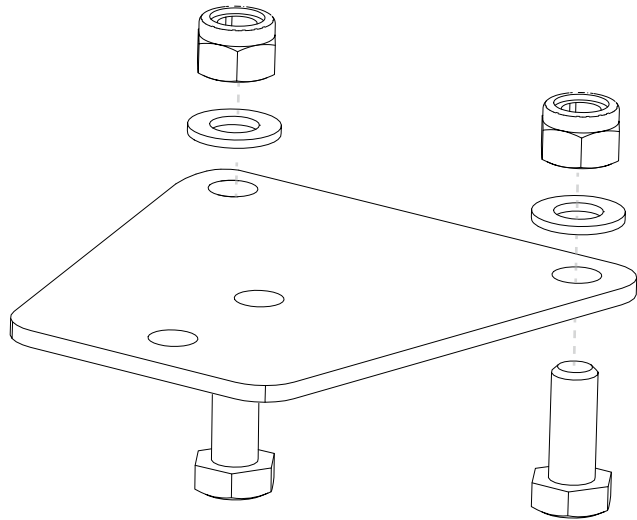

x8



RESULTAT / RESULT

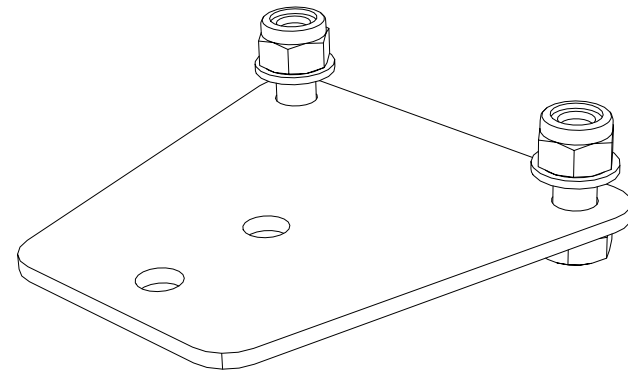

x8

7

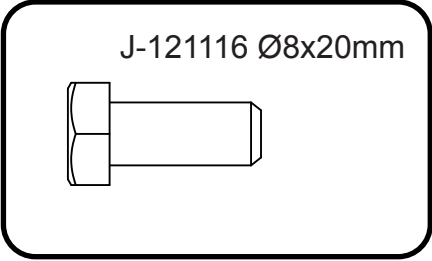

J-121518



x16

J-121615 Ø8



x16

J-121116



x16

J-150901

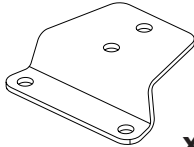

x8

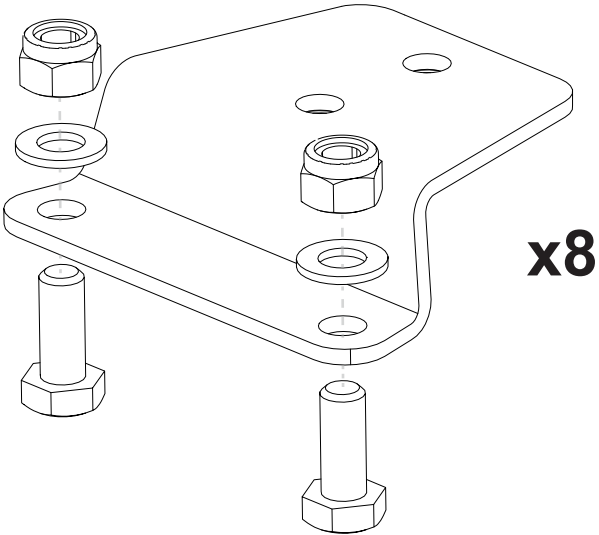

x8

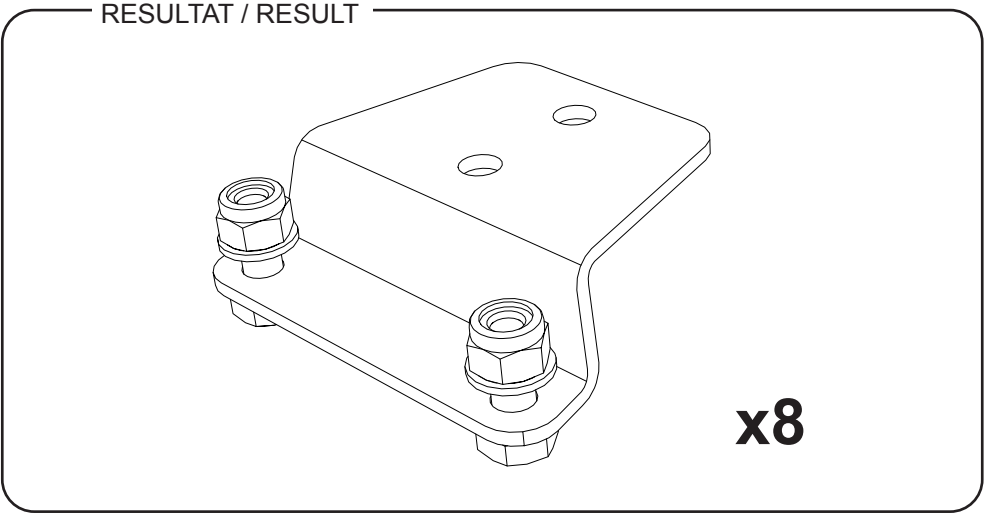

8

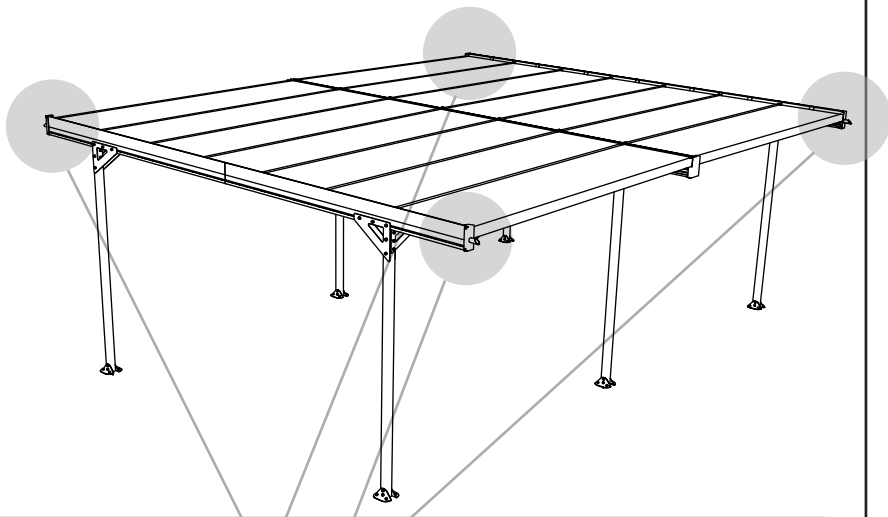
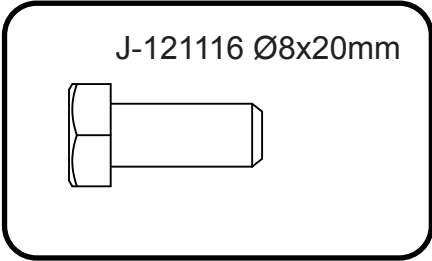

J-121518

J-121615 Ø8

J-121116

J-150902

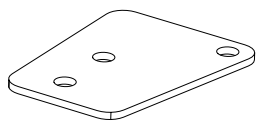

x12

x12

x12

x4

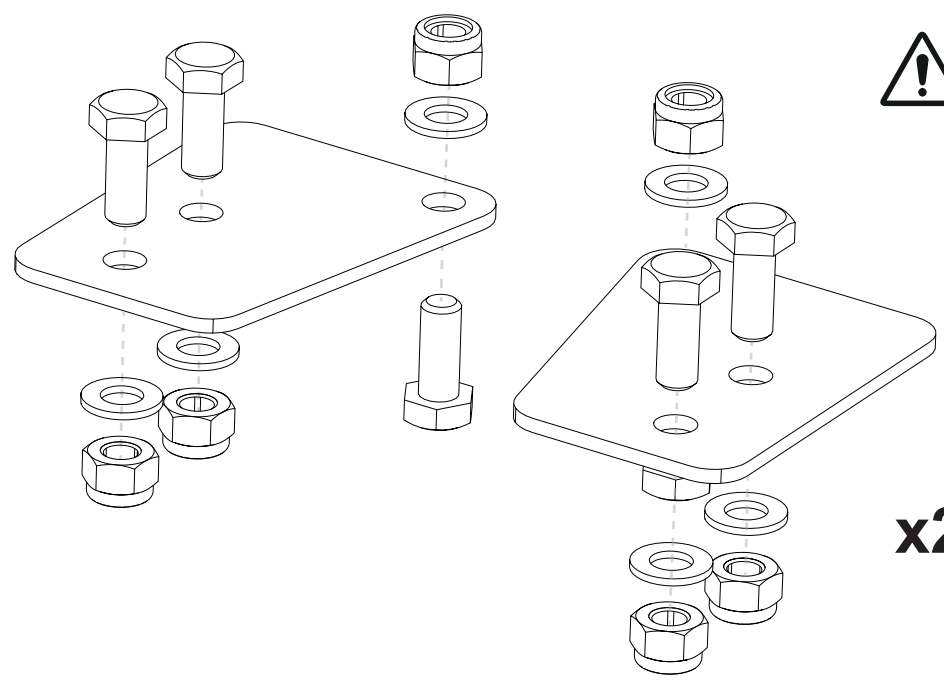

x2

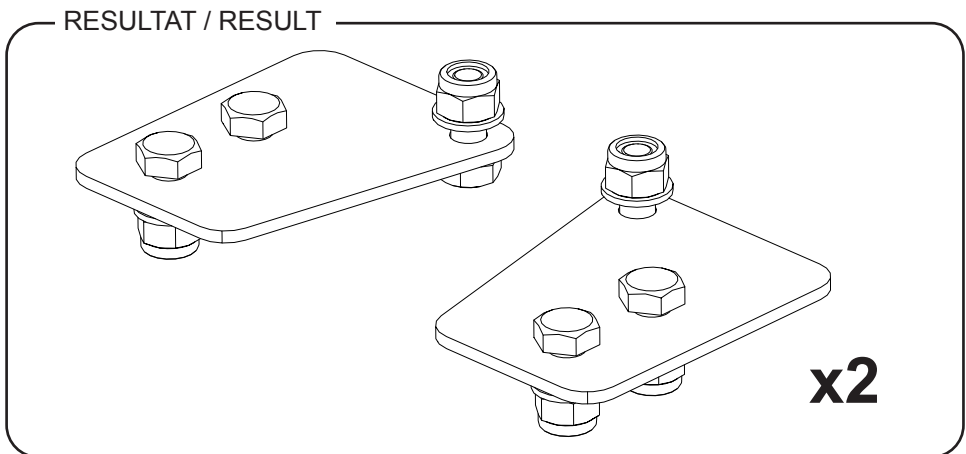

x2

9

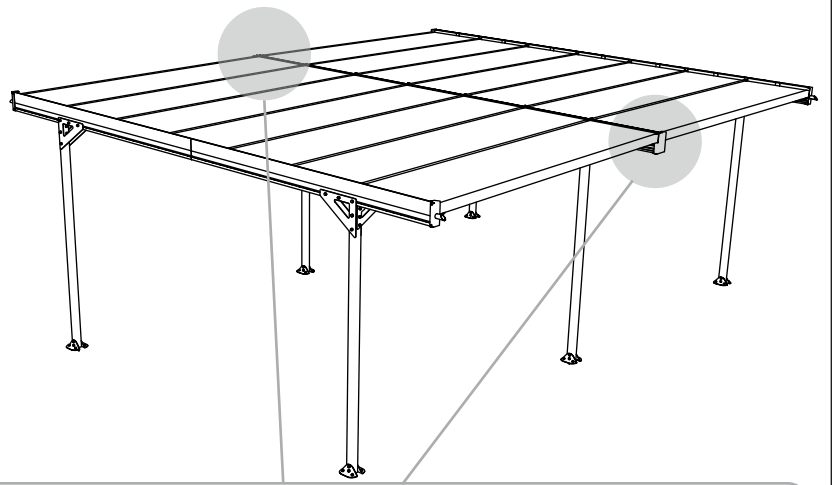
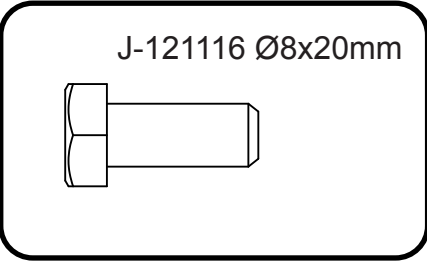

J-121518

J-121615 Ø8

J-121116

J-150903



x8



x8

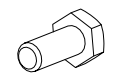

x8

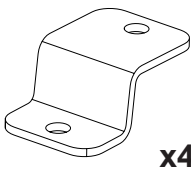

x4

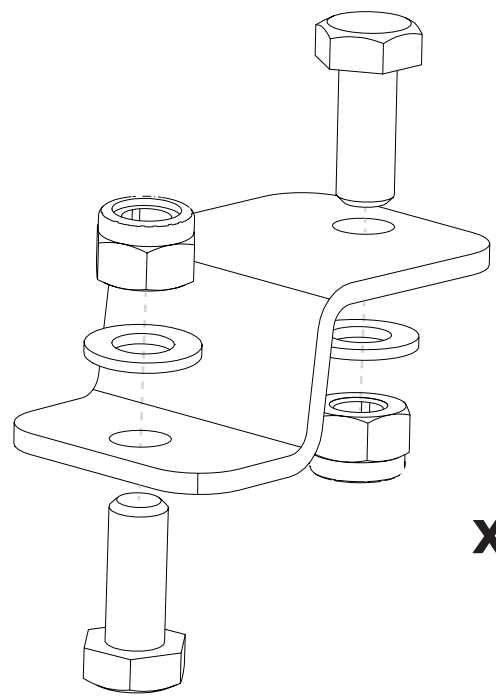

x4

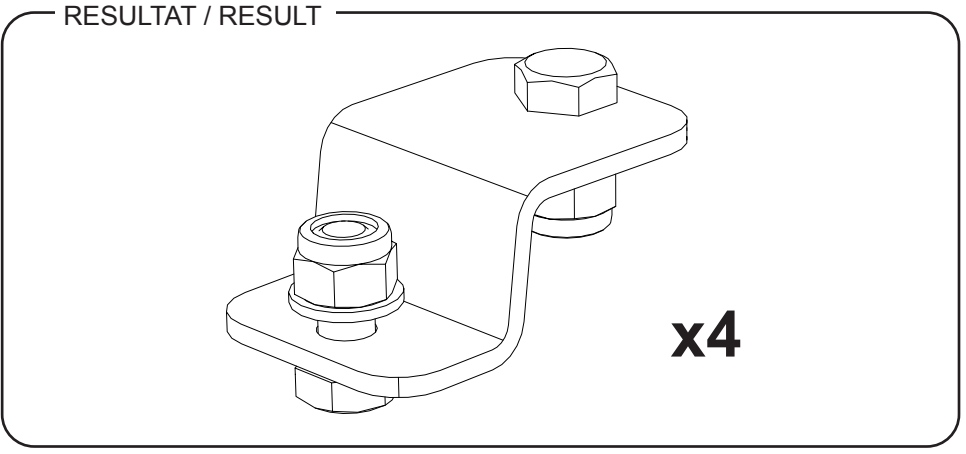
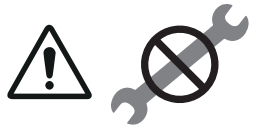

x4

10

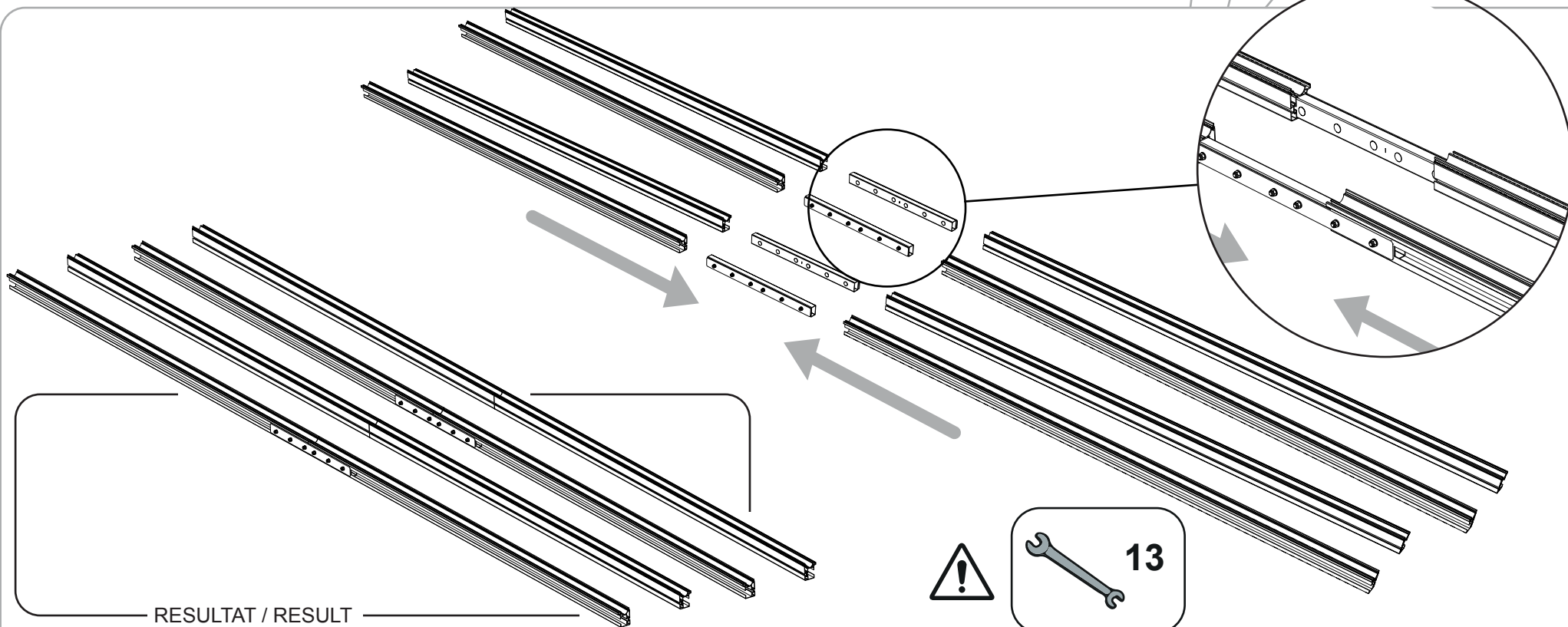
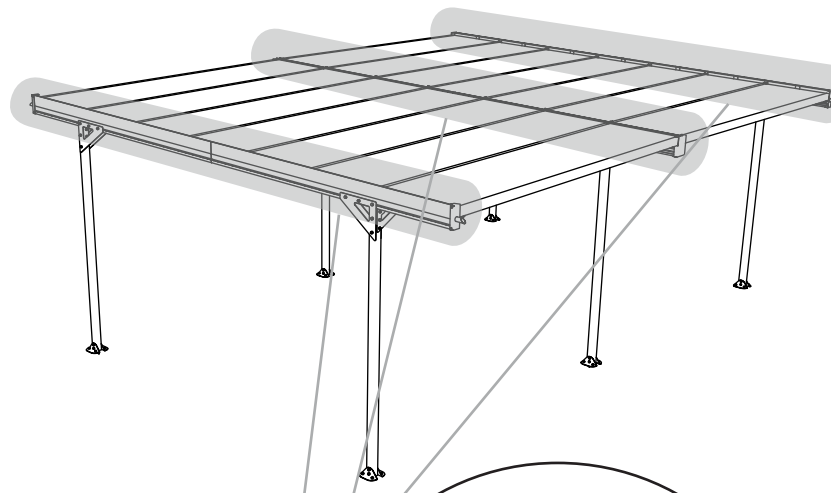
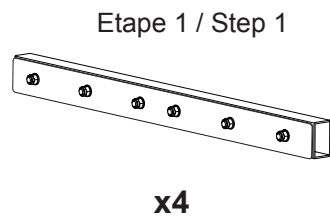
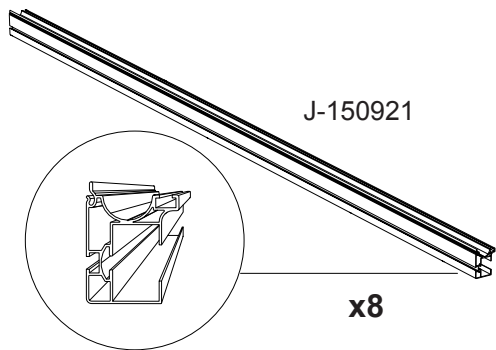

11

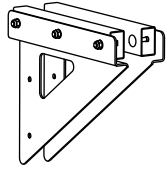

Etape 4 / Step 4

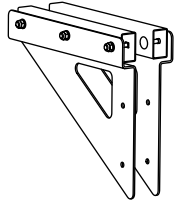

Etape 7 / Step 7

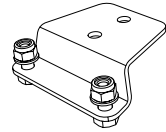

x8

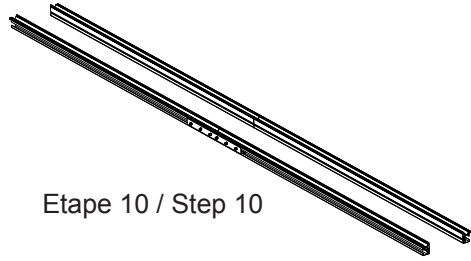
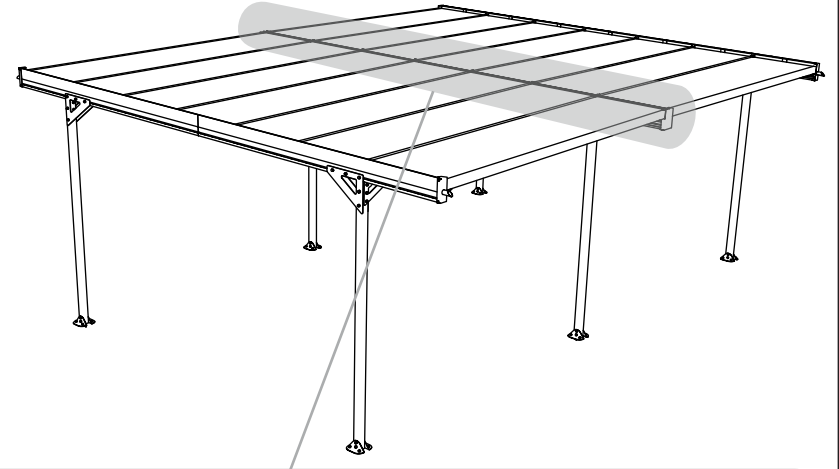

Etape 10 / Step 10

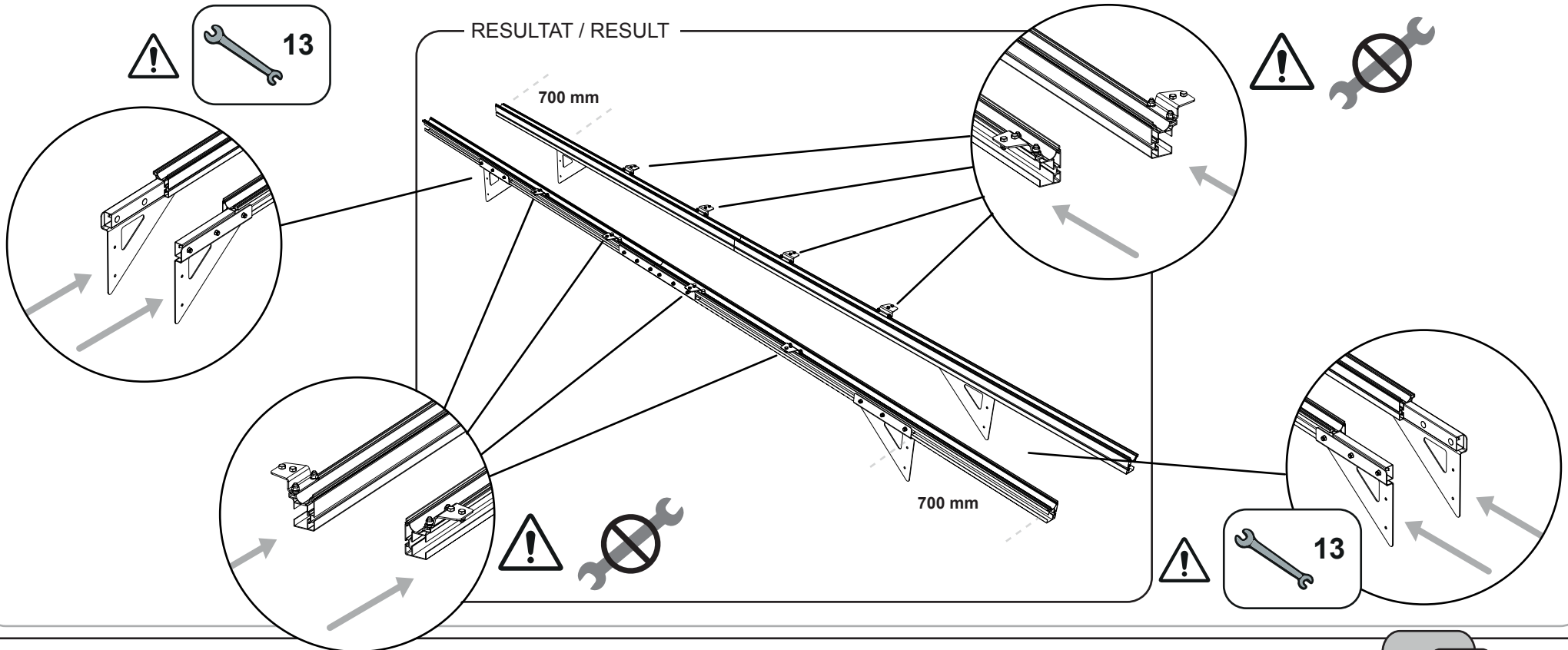

12

Etape 2 / Step 2

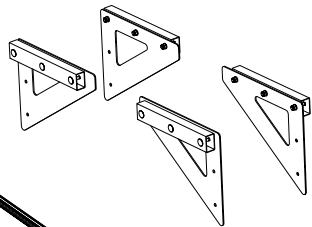

Etape 3 / Step 3

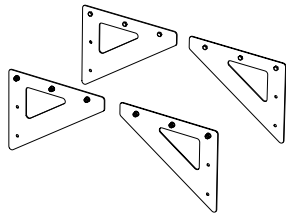

Etape 5 / Step 5

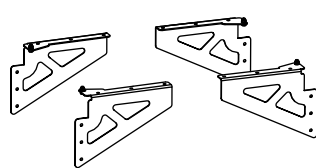

Etape 6 / Step 6

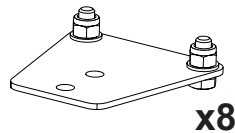

Etape 10 / Step 10

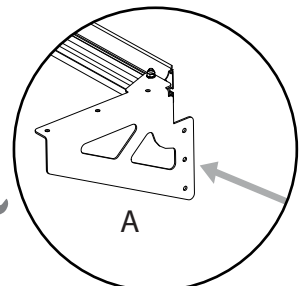
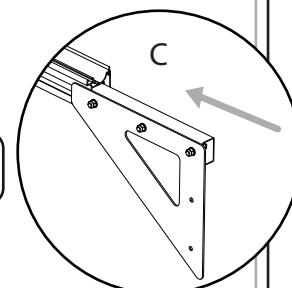
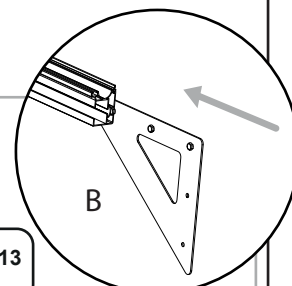
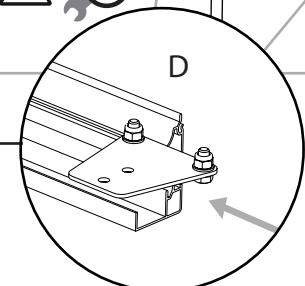
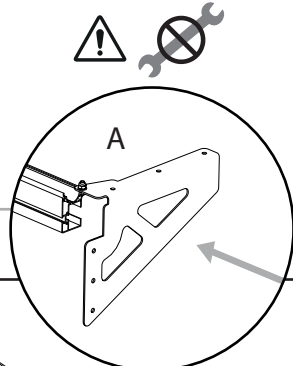
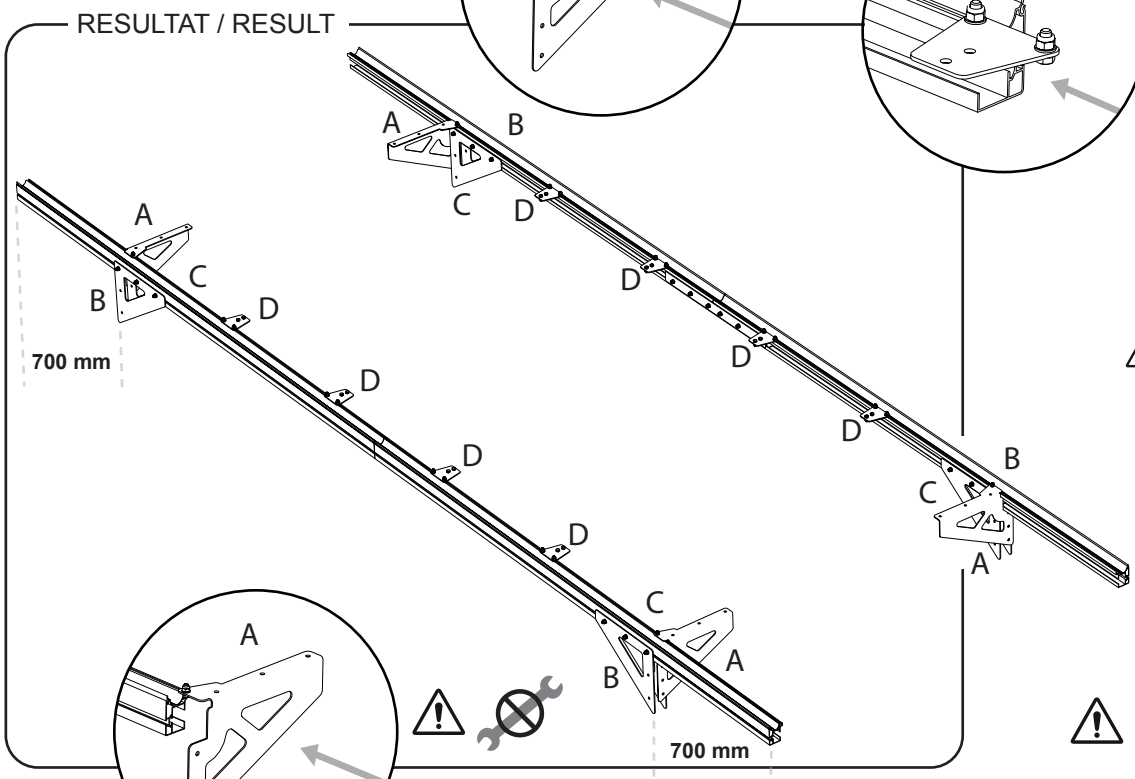
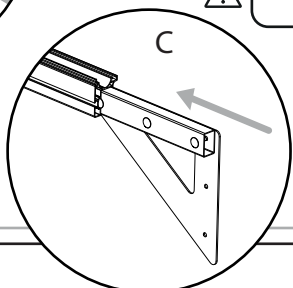
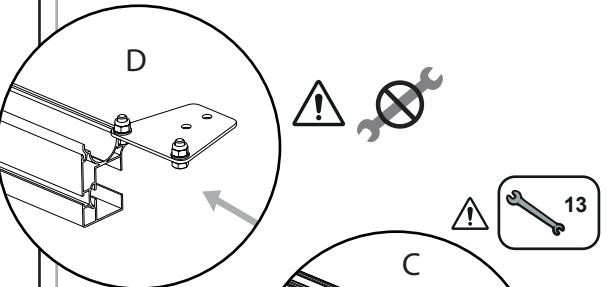
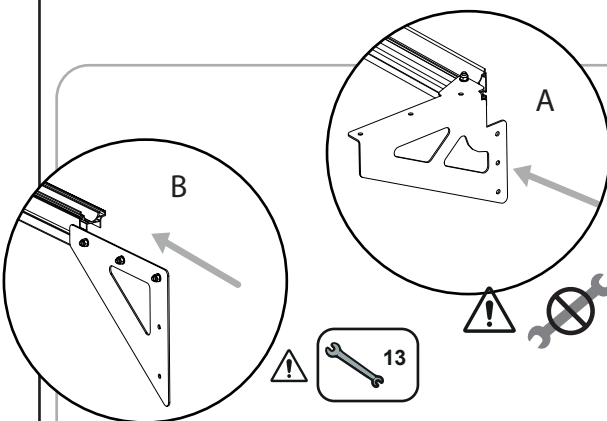
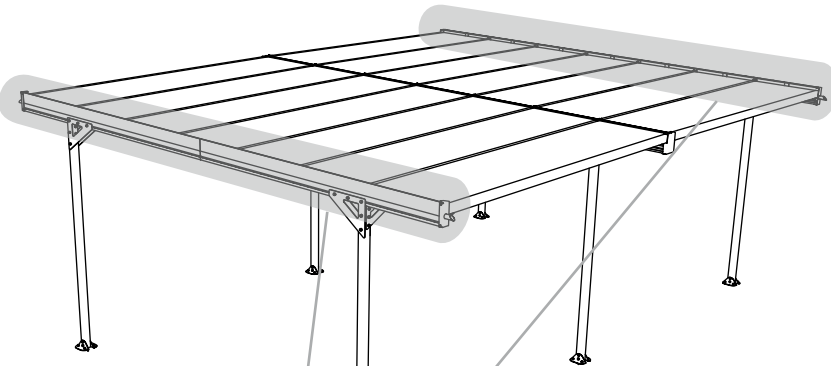
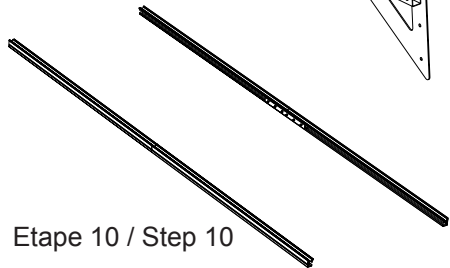

13

Etape 8 / Step 8

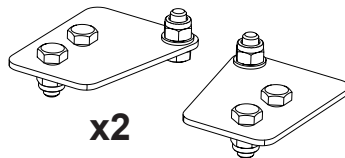

Etape 9 / Step 9

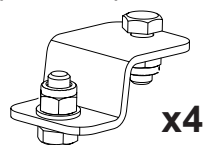

J-150920

x4

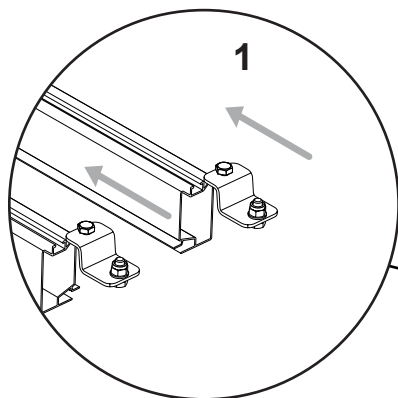
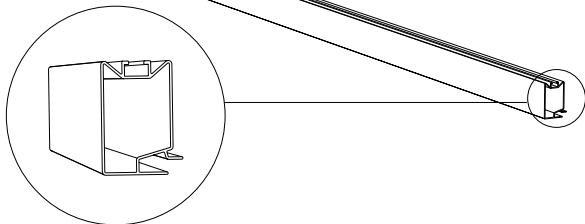
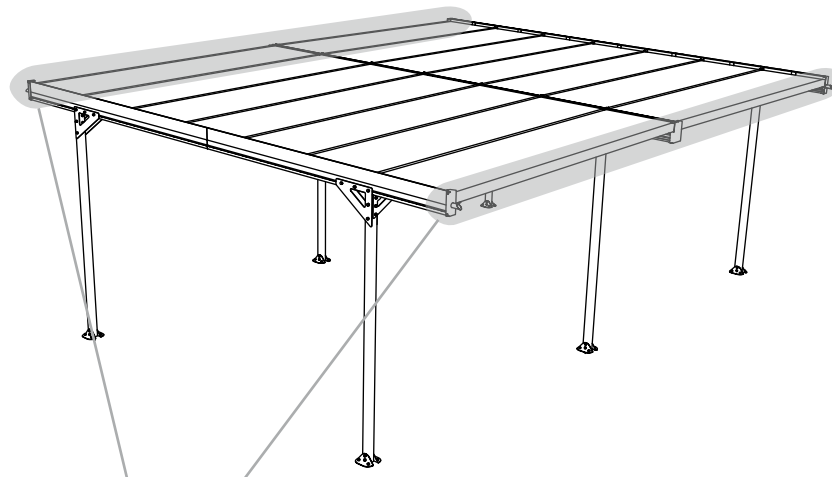

1



13

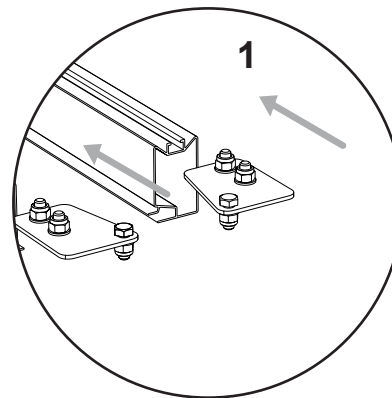

1

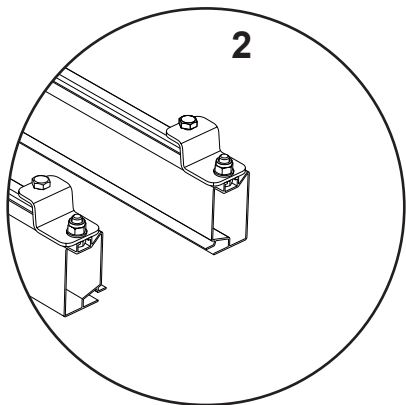

2

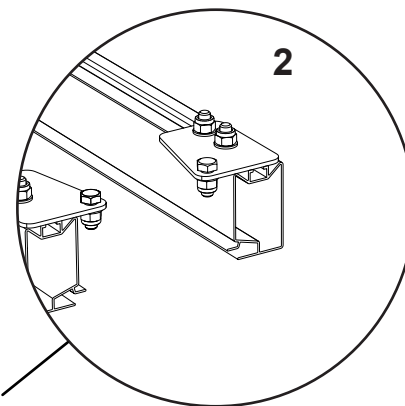

2

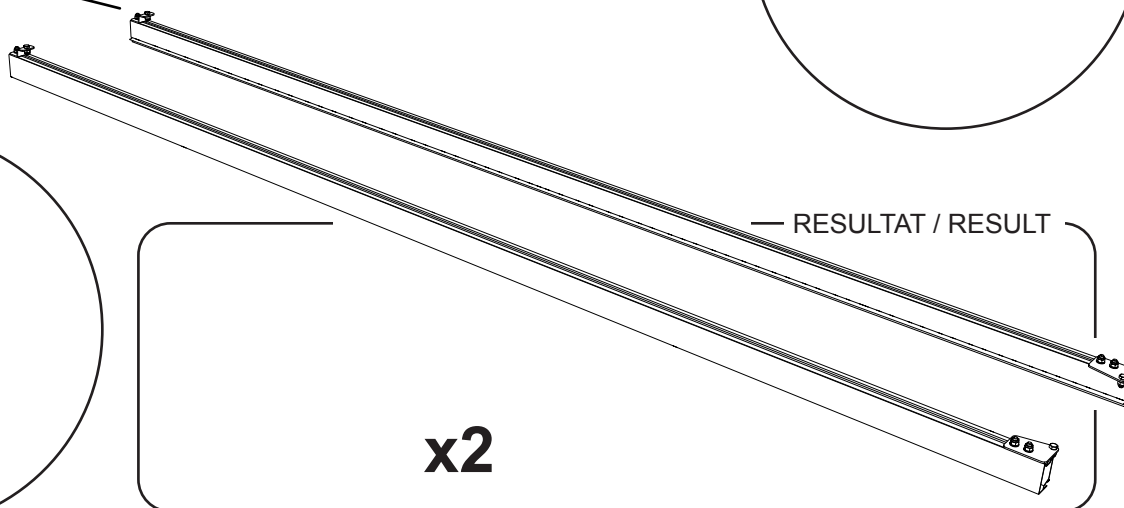

x2

— RESULTAT / RESULT

14

Etape 13 / Step 13

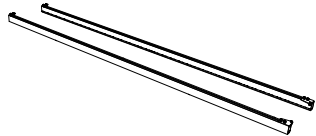

Etape 12 / Step 12

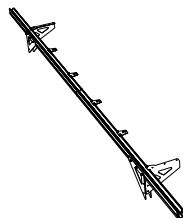

Etape 11 / Step 11

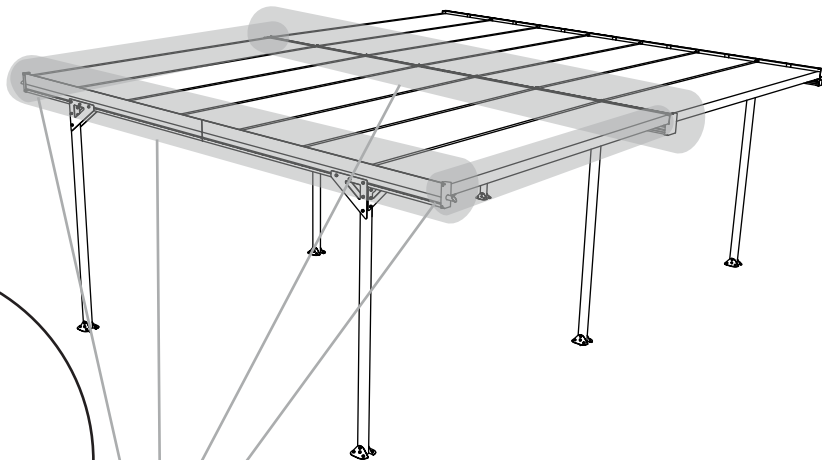

13

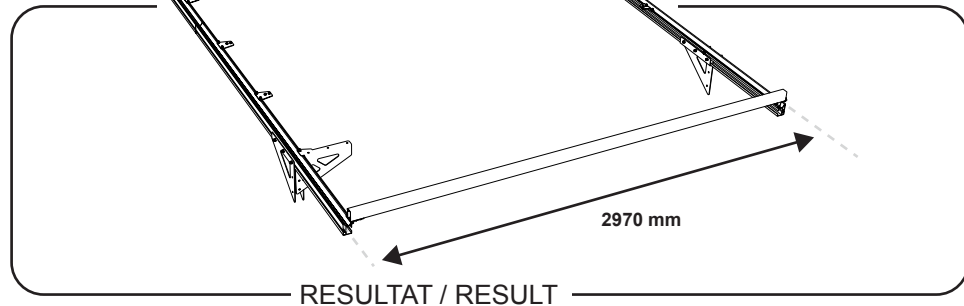
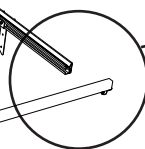
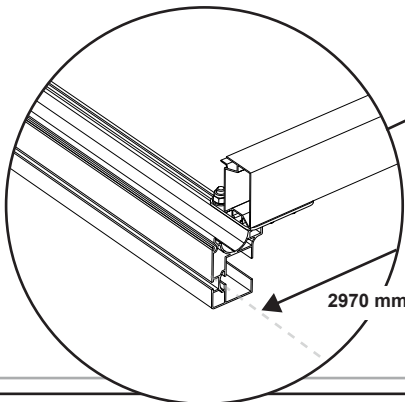
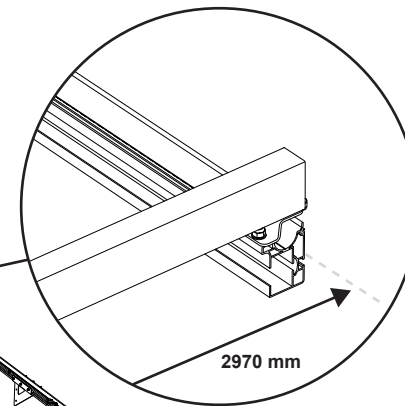
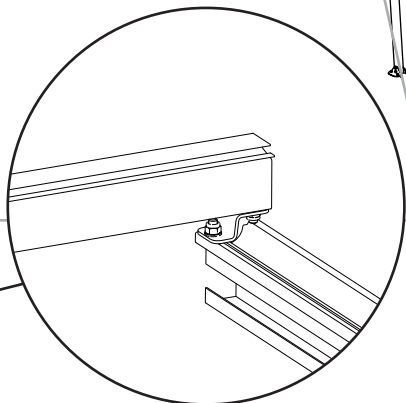
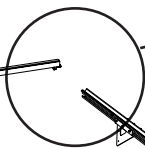
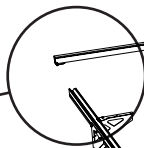
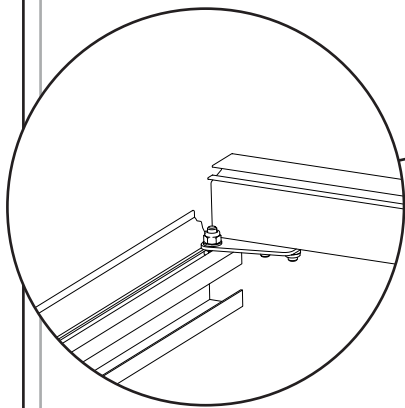

15

Etape 11 / Step 11

J-150919

x6

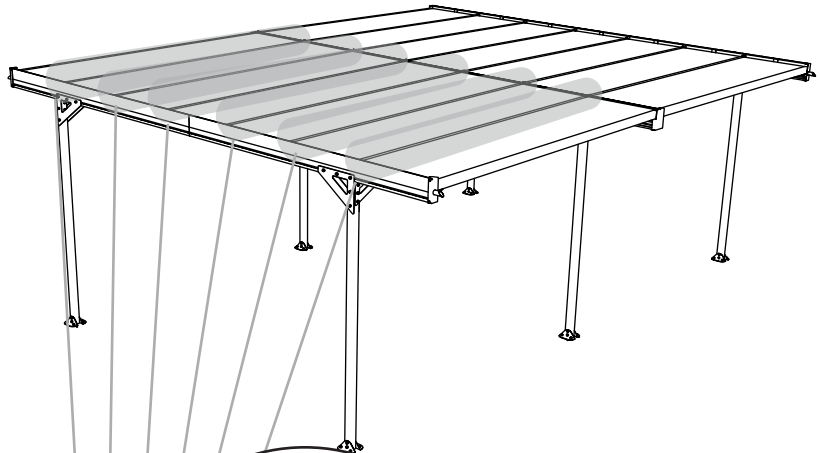
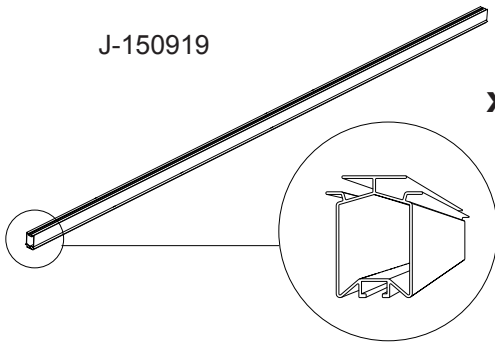
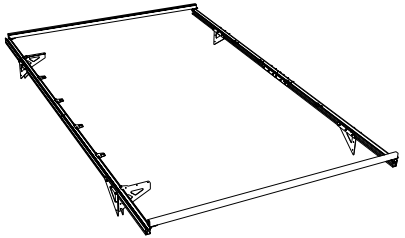

J-121518

J-121615 Ø8

J-121116

J-150925

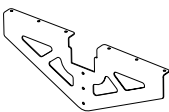
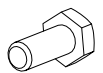

x28

x28

x28

x2

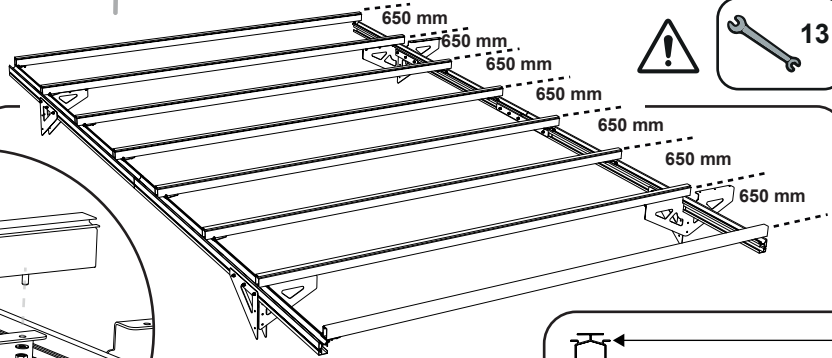
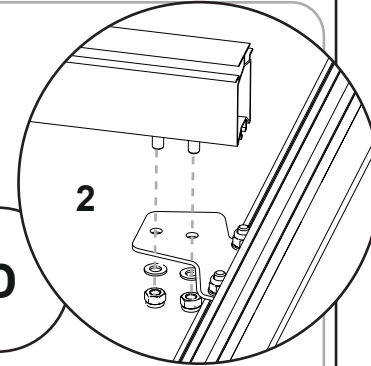
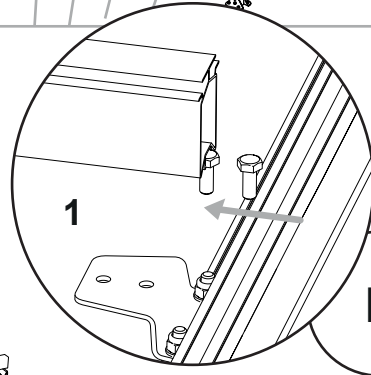
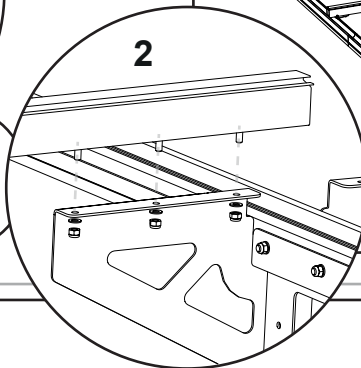
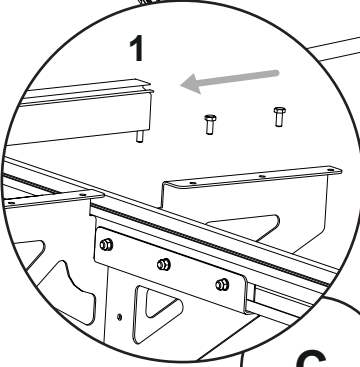
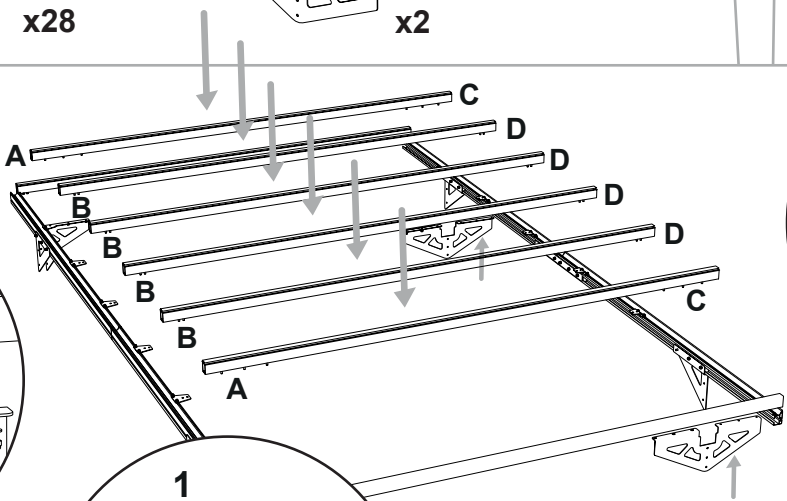
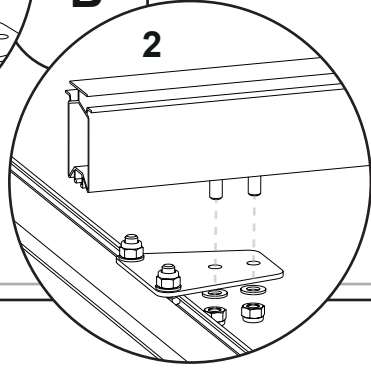
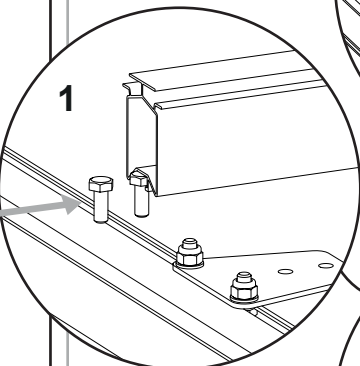
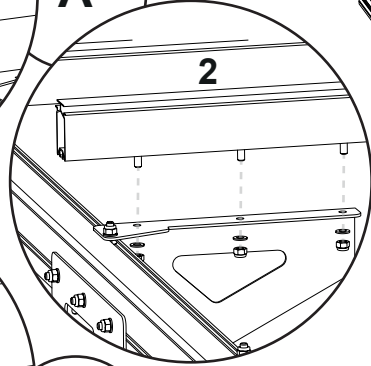
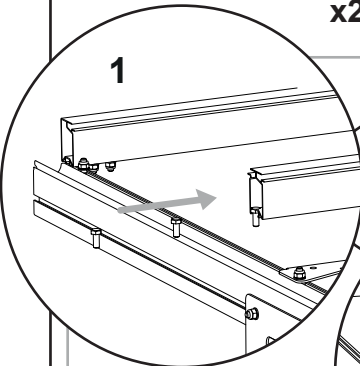

RESULTAT / RESULT



26

40

16

J-150930

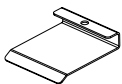

x7

J-150922

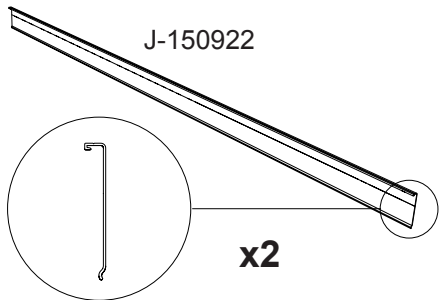

x2

Etape 15 / Step 15

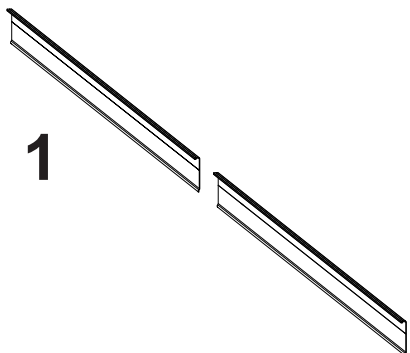
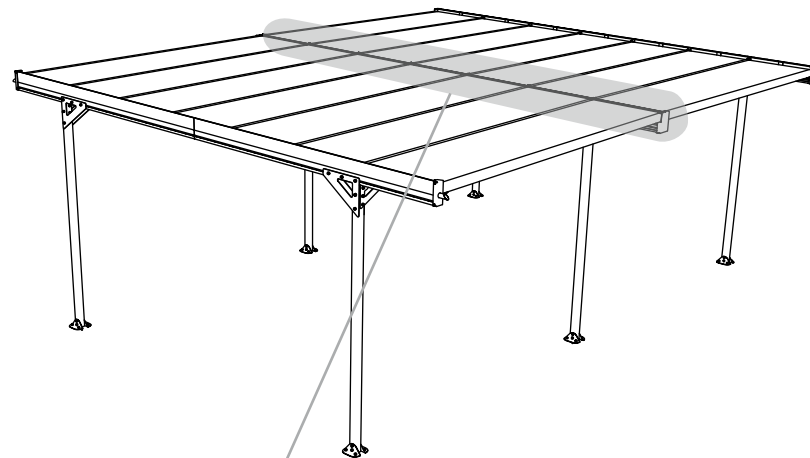
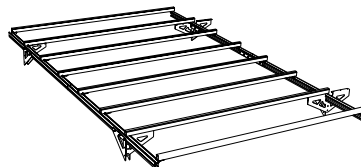

1

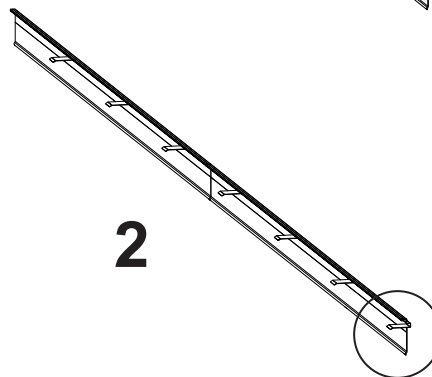

2

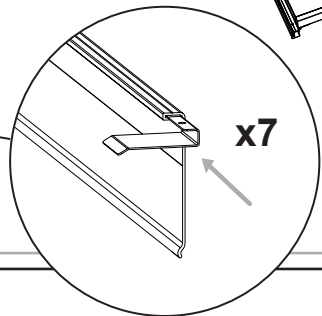

x7

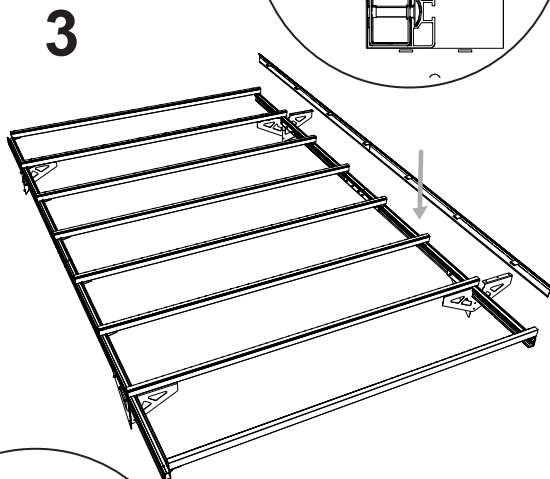

3

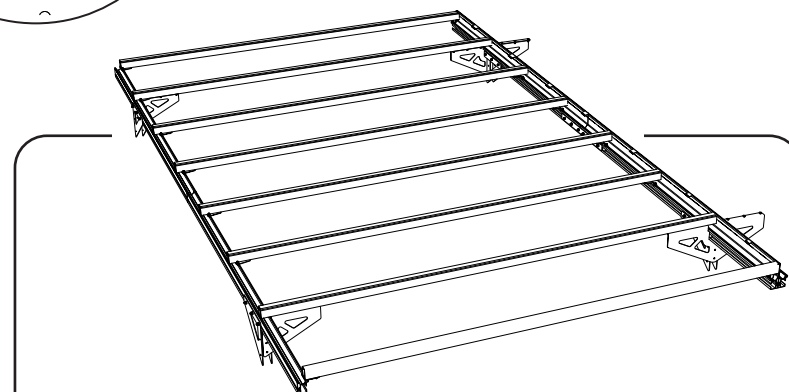
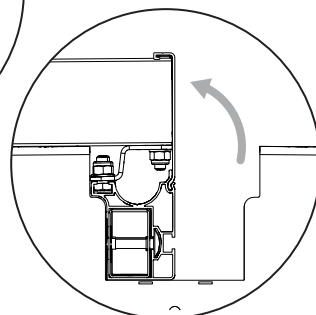
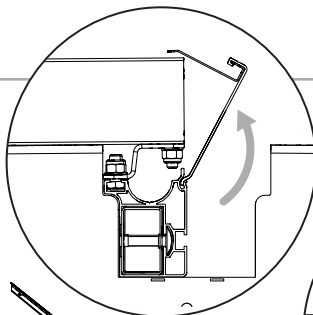

RESULTAT / RESULT

17

J-150930

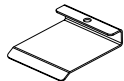

x7

J-150922

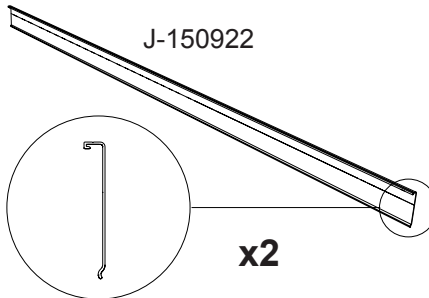

x2

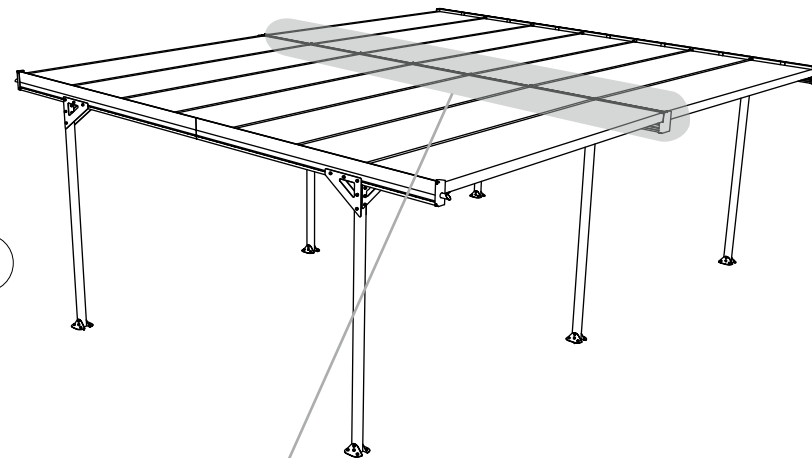

Etape 11 / Step 11

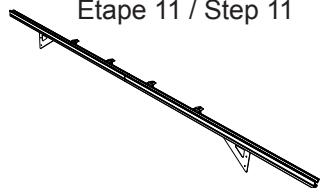

Etape 16 / Step 16

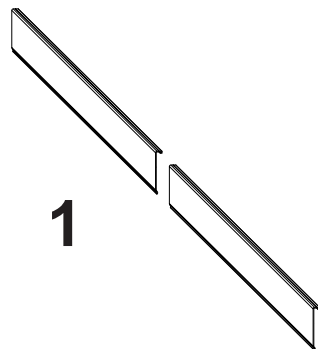
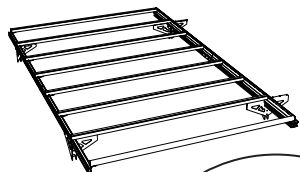

1

3

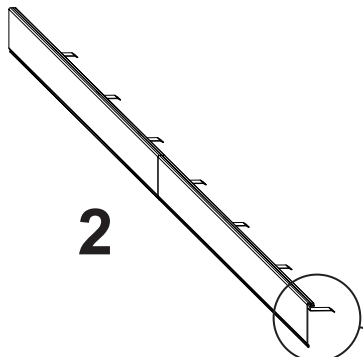
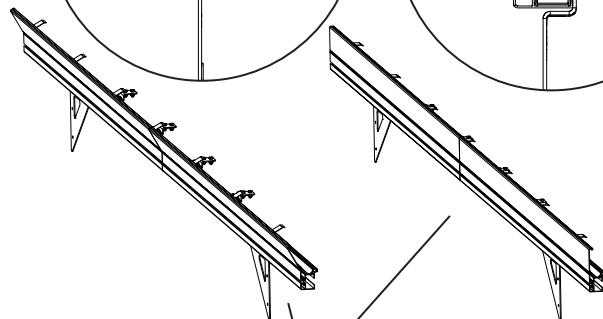

2

x7

Etape 11 / Step 11

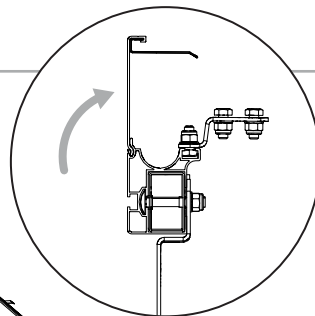

4

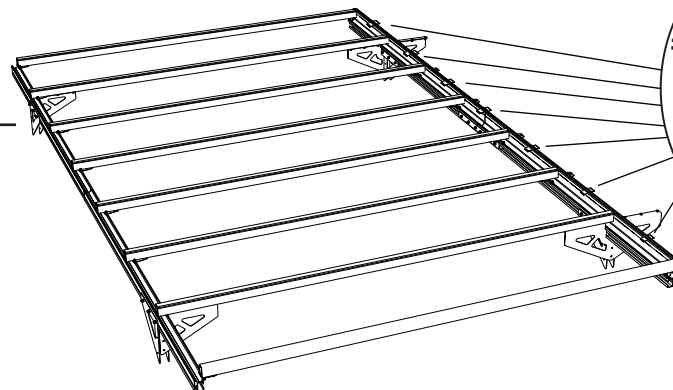
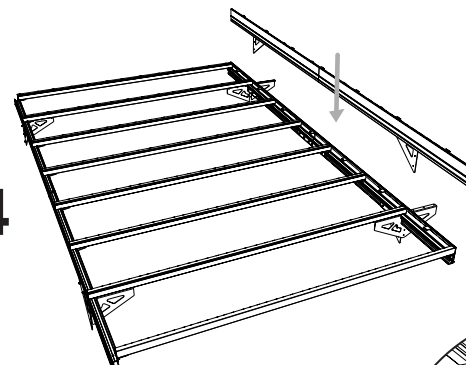

RESULTAT / RESULT

18

J-150910



x4

J-121518



x20

J-121615 Ø8



x40

J-121125 70mm



x8

J-121122 90mm



x12

Etape 17 / Step 17

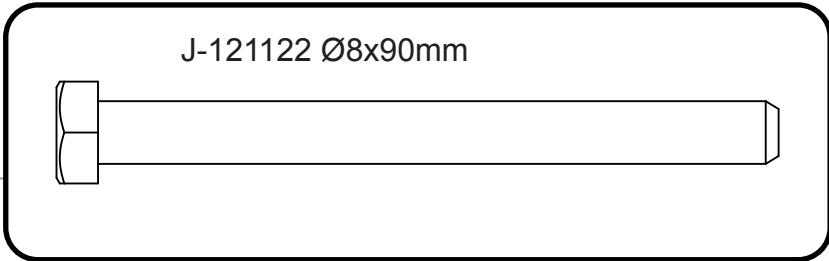
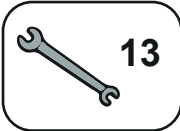

J-121122 Ø8x90mm

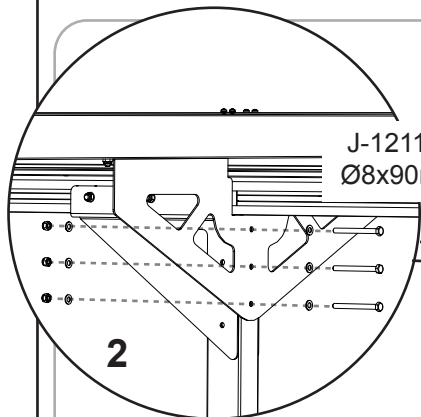
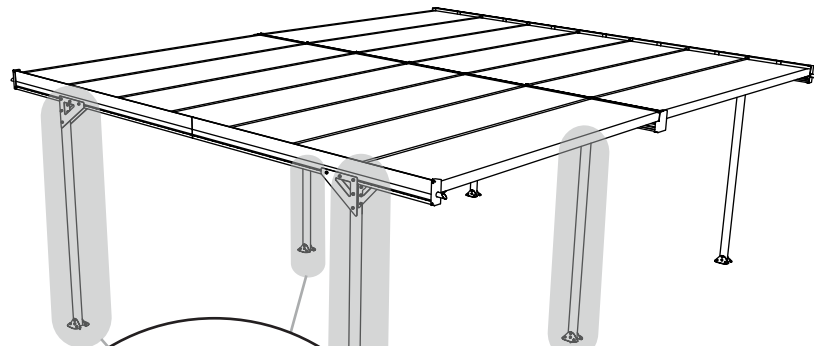
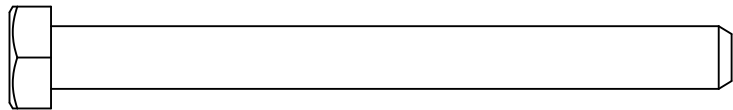

J-121122
Ø8x90mm

2

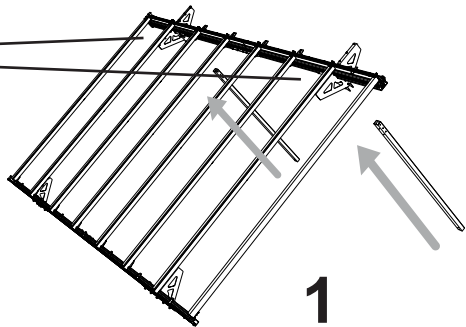

1

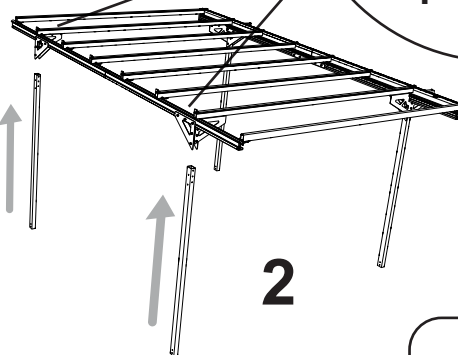

2

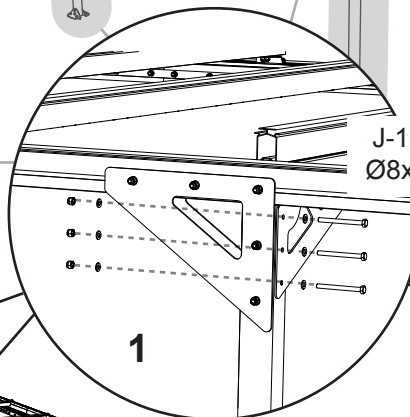

1

J-121122
Ø8x90mm

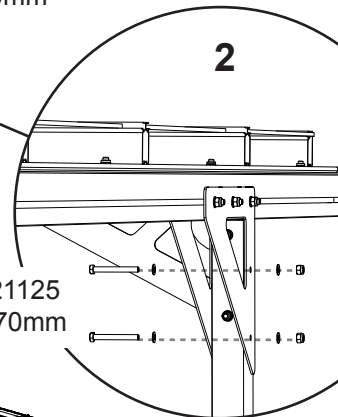

2

J-121125
Ø8x70mm

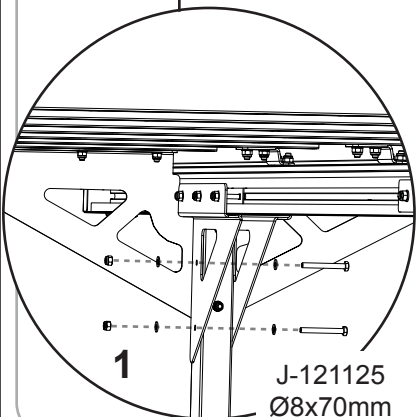

1

J-121125
Ø8x70mm

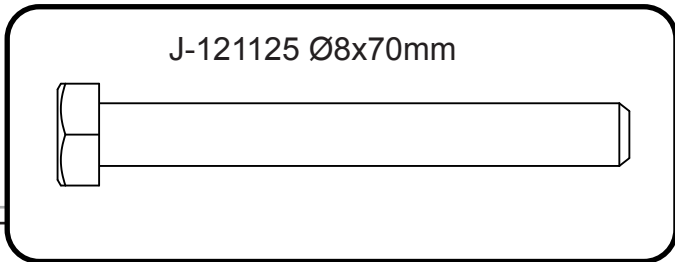

J-121125 Ø8x70mm

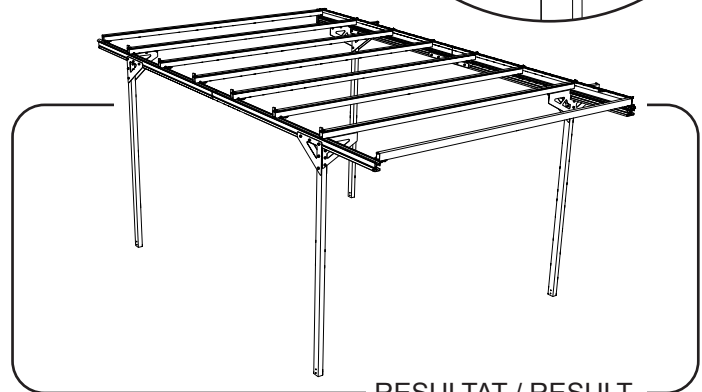
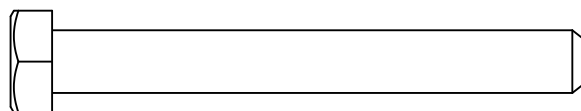

RESULTAT / RESULT

19

J-150904



x8

J-121518



x8

J-121615 Ø8



x16

J-121125 70mm

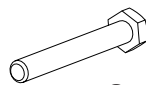

x8

Etape 18 / Step 18

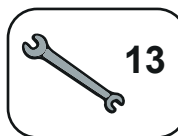
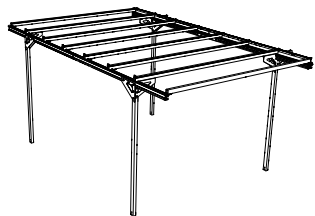

J-121125 Ø8x70mm

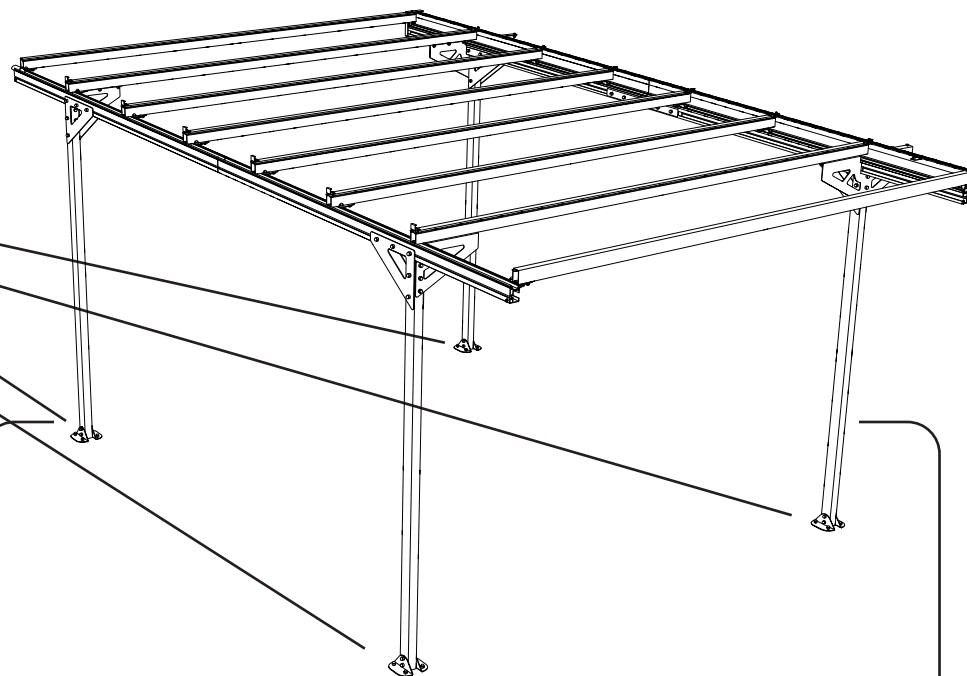
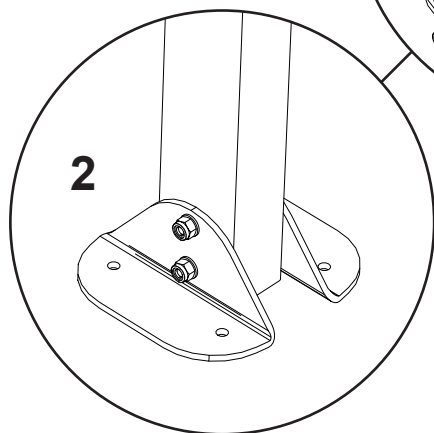
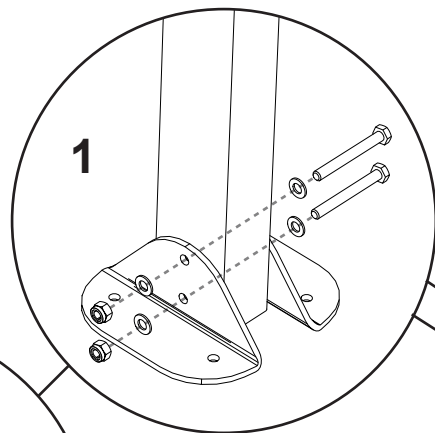
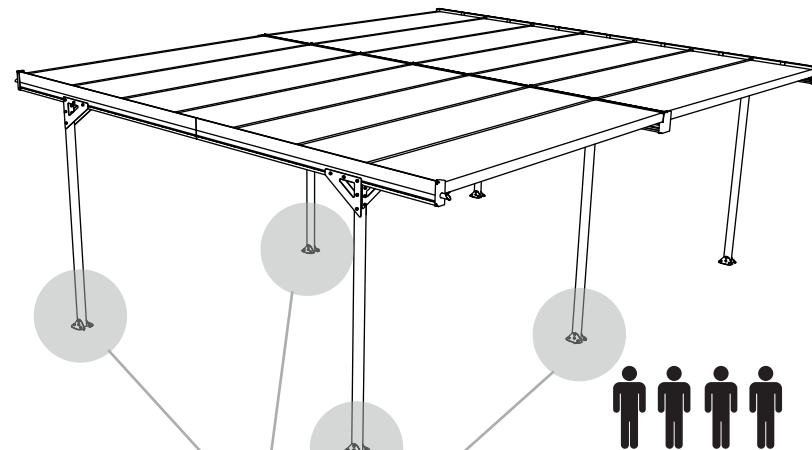
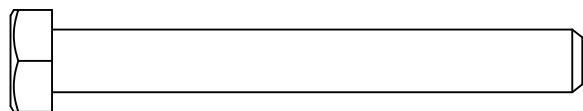

RESULTAT / RESULT

ANCORAGE / ANCHORING

J-121374

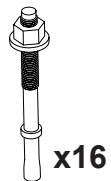

FR : Foret Ø8 béton non fourni
EN : Ø8 concrete drill bit not supplied
DE : Ø8 Betonbohrer nicht mitgeliefert
NL : Ø8 betonboor niet meegeleverd
IT : Punta per calcestruzzo Ø8 non fornita
ES : Broca de hormigón Ø8 no suministrada
PT : Broca para betão Ø8 não fornecida

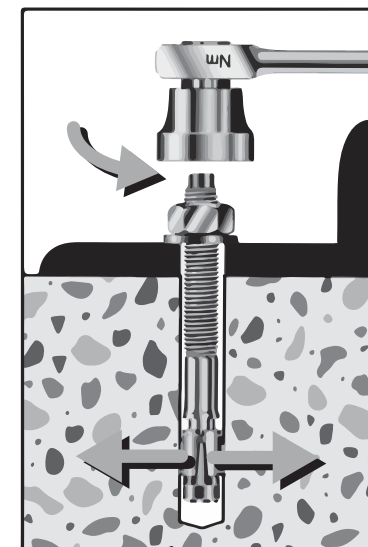
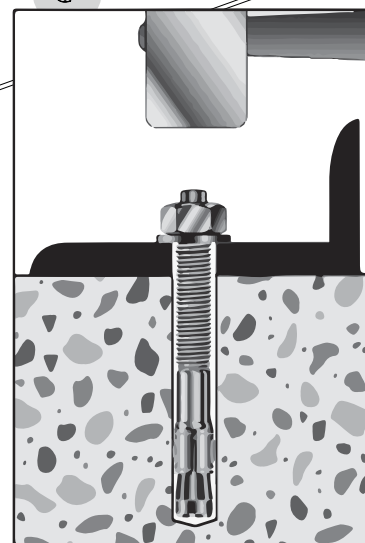
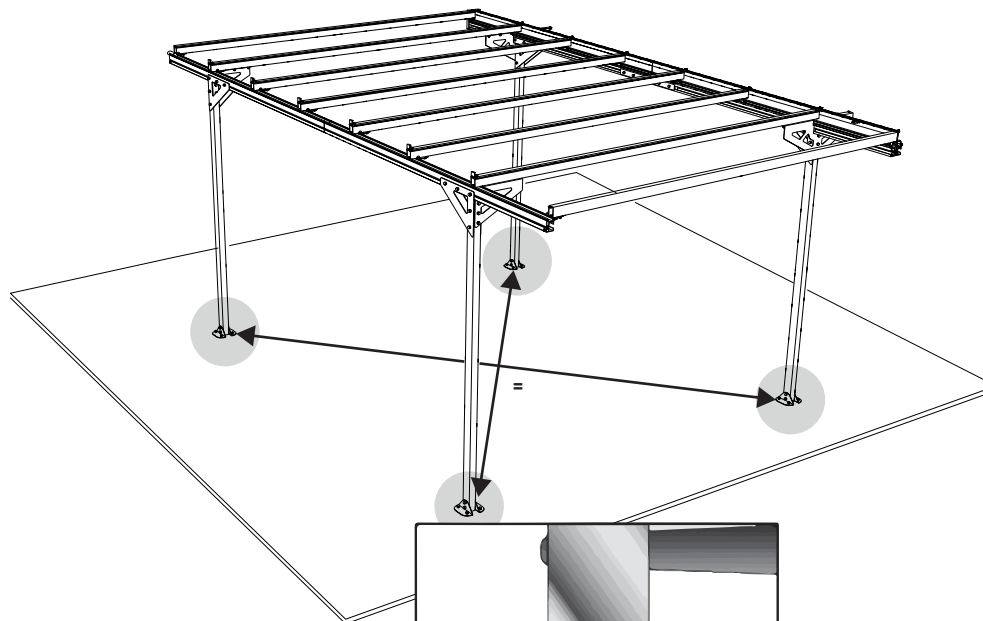
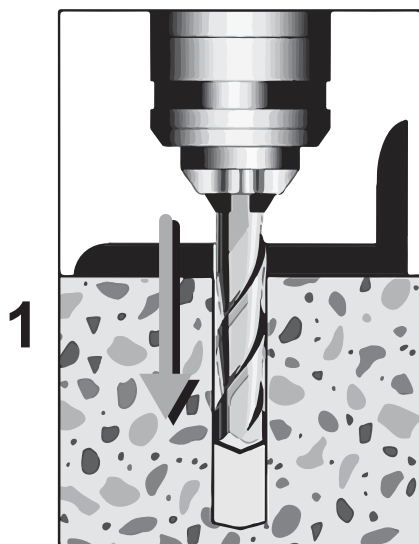
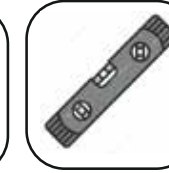
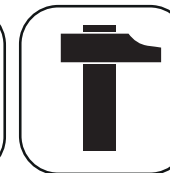

20

Etape 19 / Step 19



J-150906

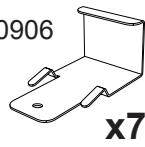

x7

J-150905

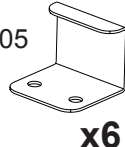

x6

J-121341

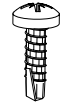

x12

J-121616 Ø5



x12

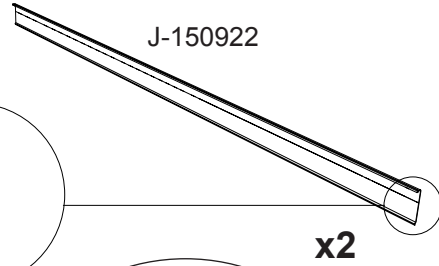

J-150922

x2

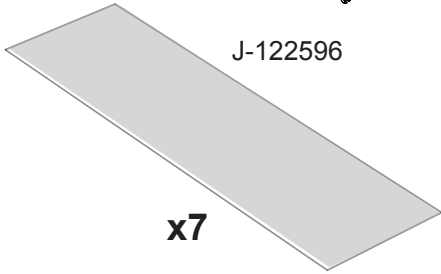
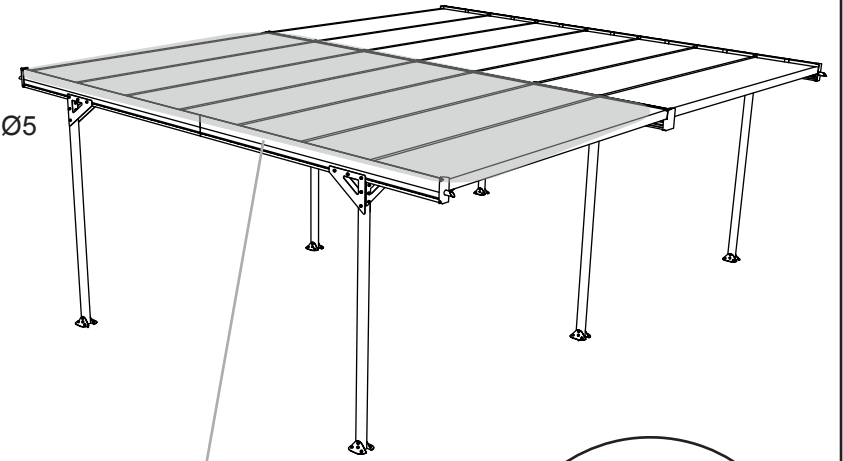

J-122596

x7

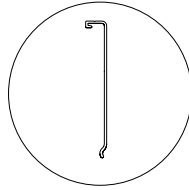

1

FR : Ruban microperforé
 EN : Vent tape
 DE : Mikroperforiertes Klebeband
 NL : Plakband met microperforaties
 IT : Nastro con microfori
 ES : Cinta microperforada
 PT : Fita microperfurada

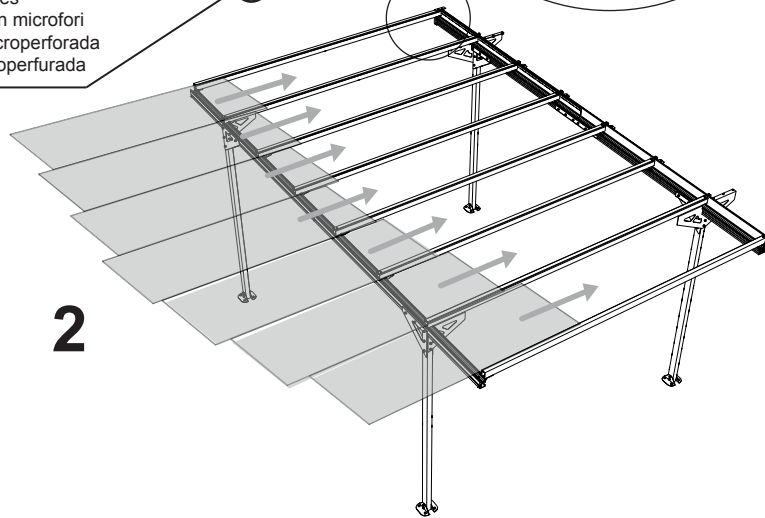

2

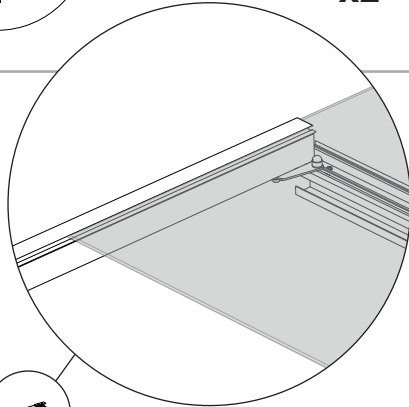

3

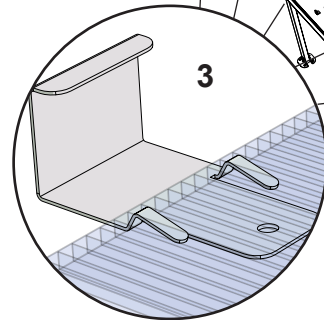

3

FR : Les pattes de l'attache s'insèrent dans les alvéoles
 EN : The fixing supports slide in between the connective ribbing
 DE : Die Befestigungslaschen werden in die Öffnungen eingeführt
 NL : De haakjes van het bevestigingsstuk moeten in de openingen worden geschoven
 IT : Le piastre di aggancio si inseriscono nelle apposite aperture
 ES : Las patillas de unión se introducen en las cavidades
 PT : Os ganchos de fixação devem ser inseridos nos alvéolos

4

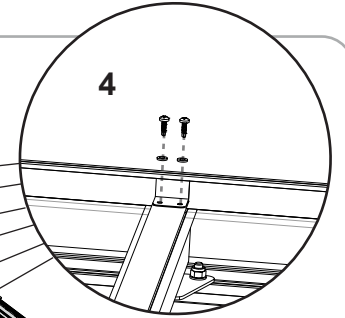

1

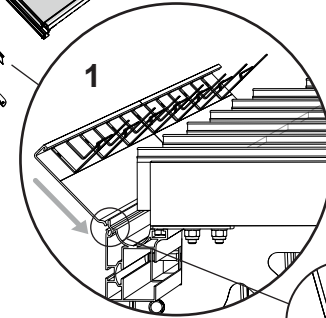

2

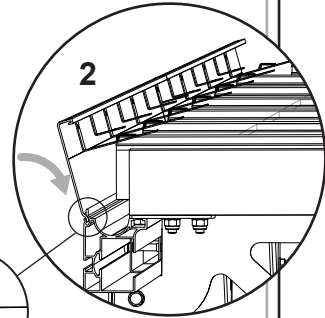

21

J-121125 70mm

J-121122 90mm

Etape 12 / Step 12

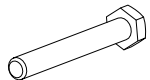

x8



x6

J-150910

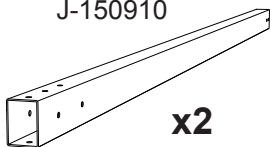

x2

J-121518



x14

J-121615 Ø8



x28

J-150904

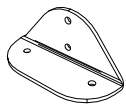

x4

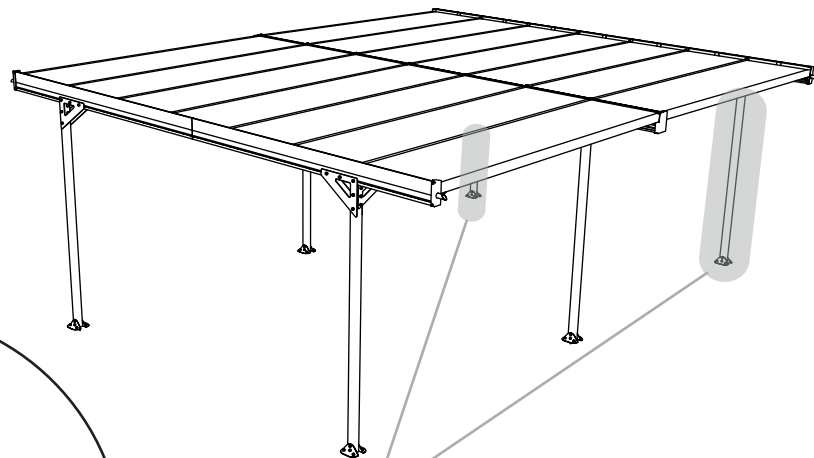
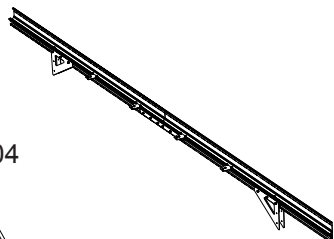

J-121122 Ø8x90mm

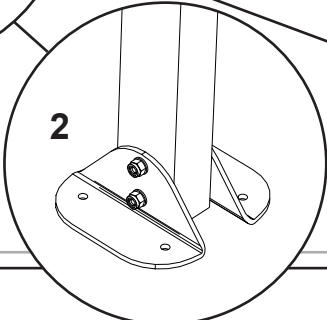
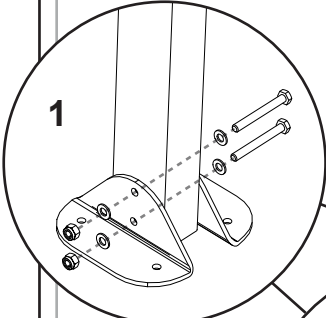
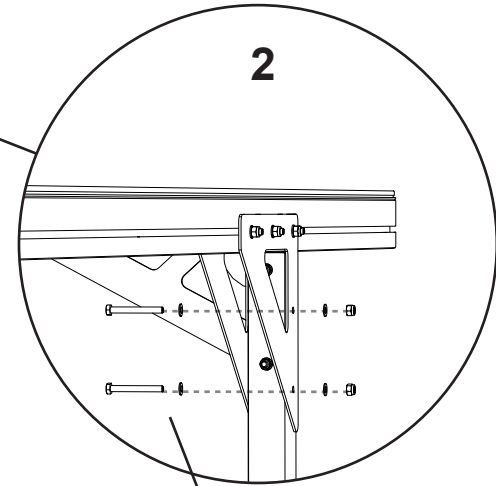
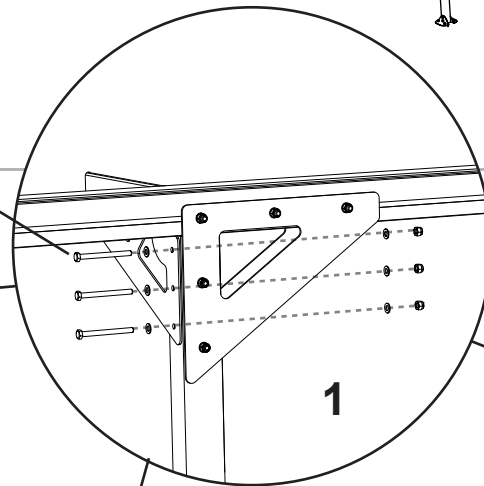
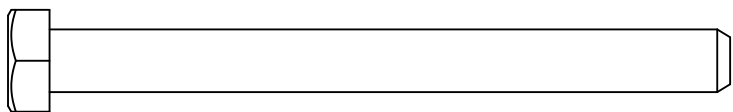

2

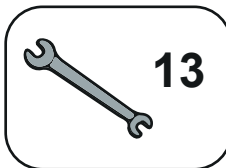

13

J-121125 Ø8x70mm

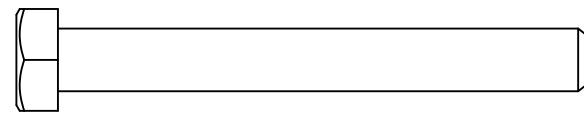

22

Etape 21 / Step 21

J-150919

x6

J-121116 Ø8x20mm

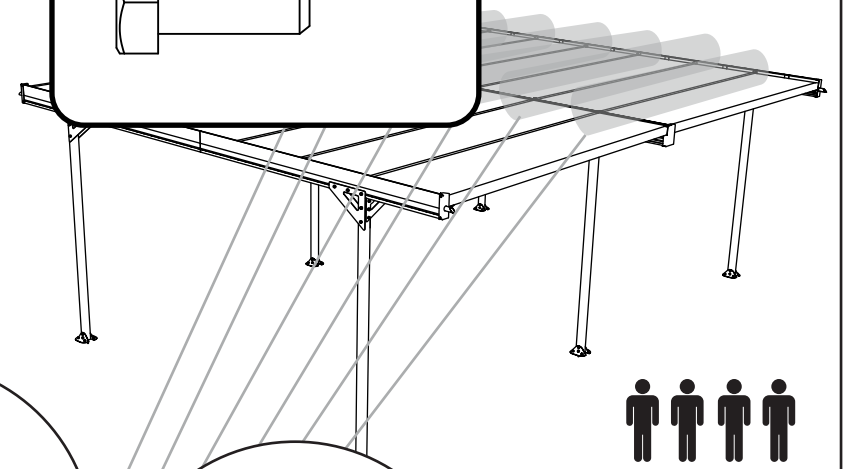
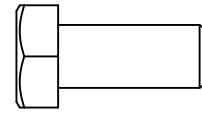

Etape 20 / Step 20



J-121518



x28

J-121615 Ø8



x28

J-121116



x28

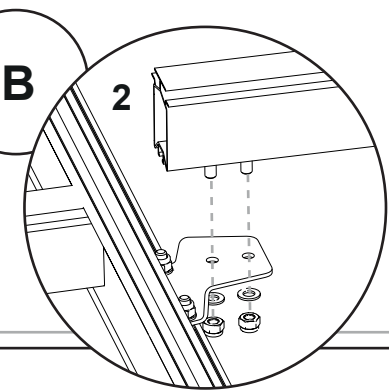
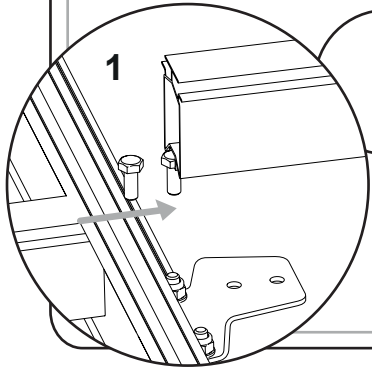
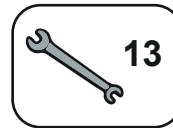
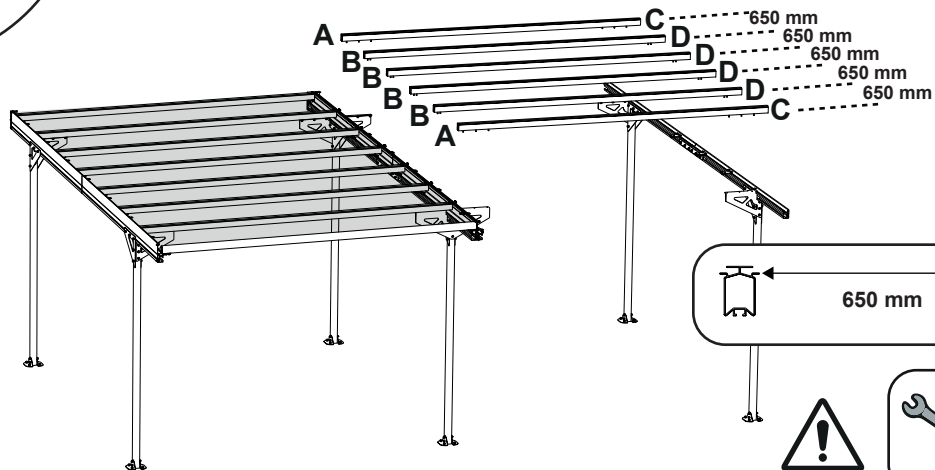
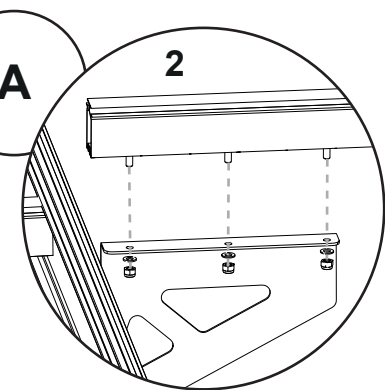
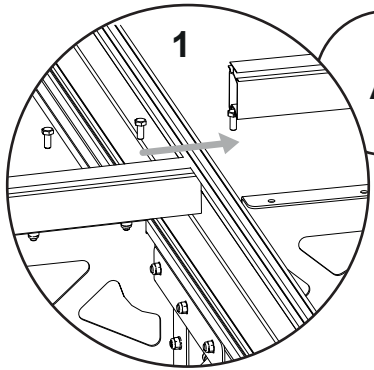
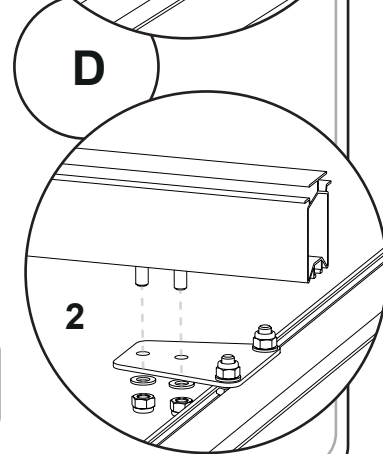
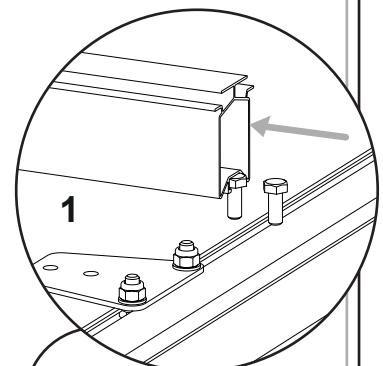
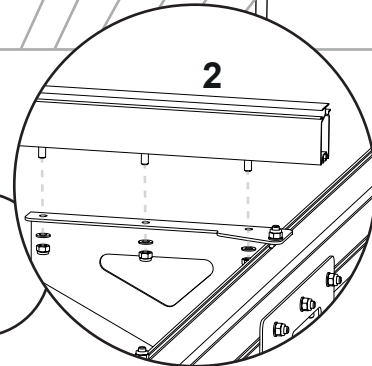
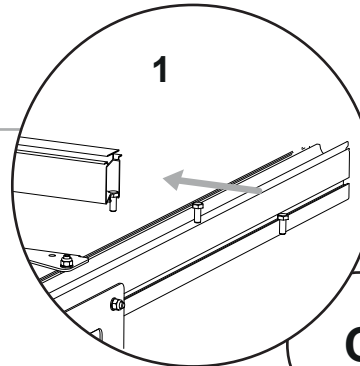
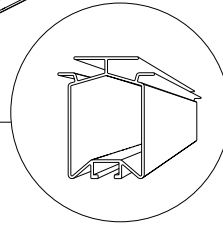

23

Etape 22 / Step 22

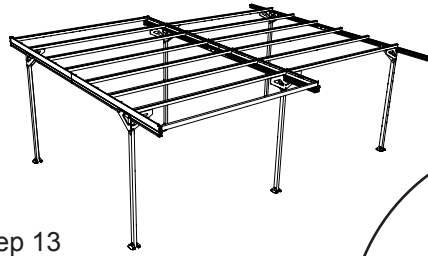

J-121341



x24

J-121616 Ø5



x24

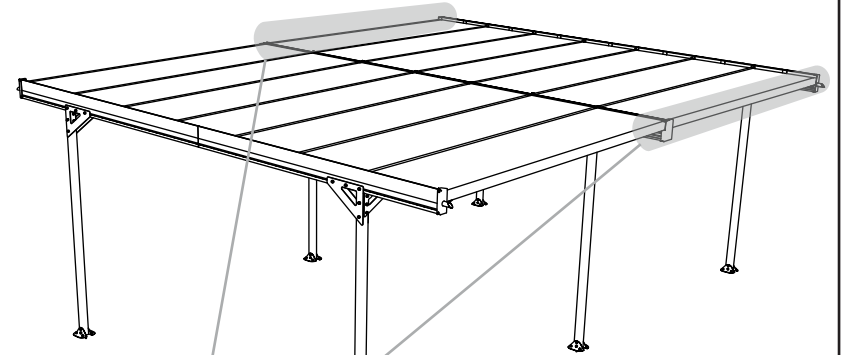

Etape 13 / Step 13

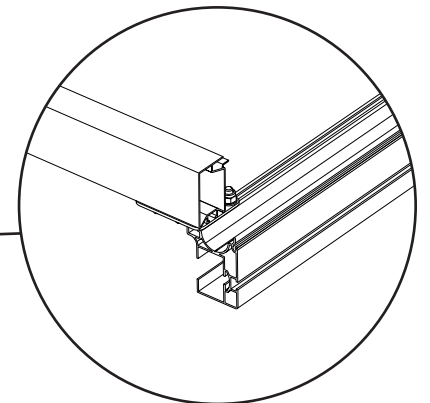
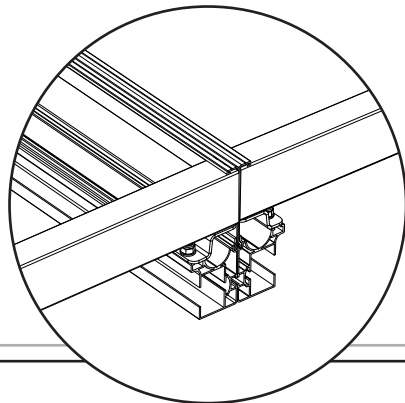
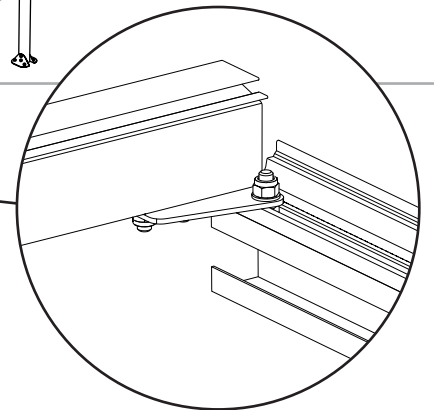
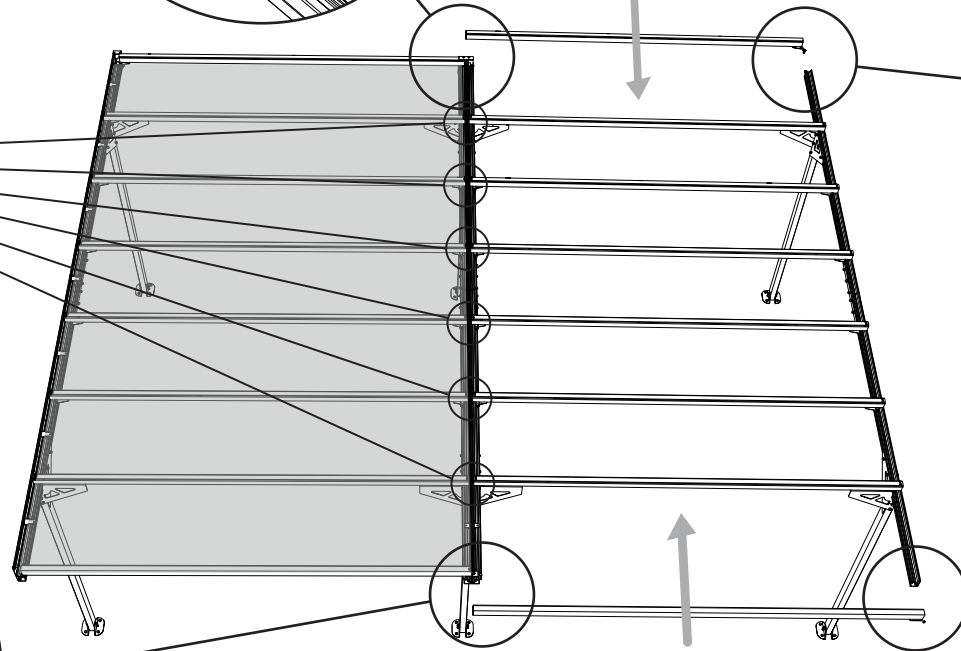
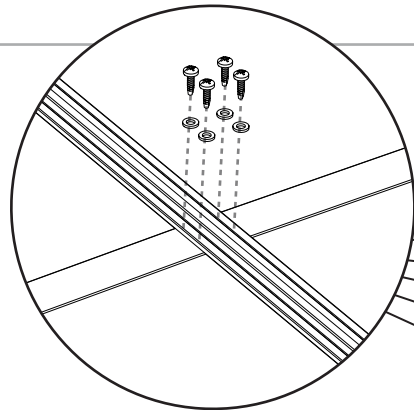
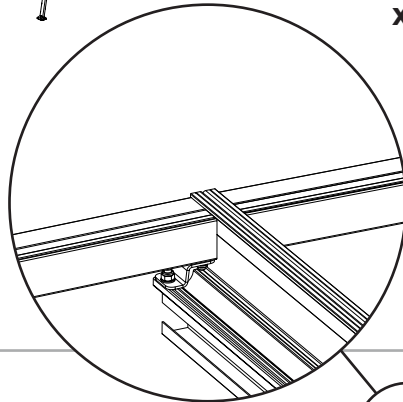
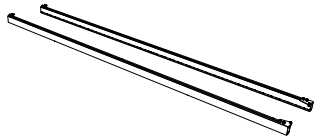

13

ANCORAGE / ANCHORING

J-121374



x8

FR : Foret Ø8 béton non fourni
EN : Ø8 concrete drill bit not supplied
DE : Ø8 Betonbohrer nicht mitgeliefert
NL : Ø8 betonboor niet meegeleverd
IT : Punta per calcestruzzo Ø8 non fornita
ES : Broca de hormigón Ø8 no suministrada
PT : Broca para betão Ø8 não fornecida

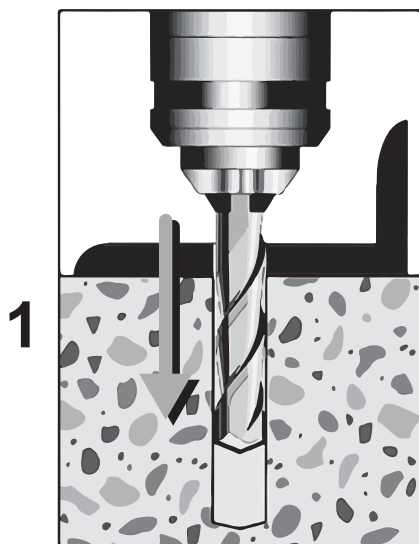
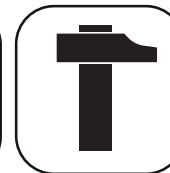

1

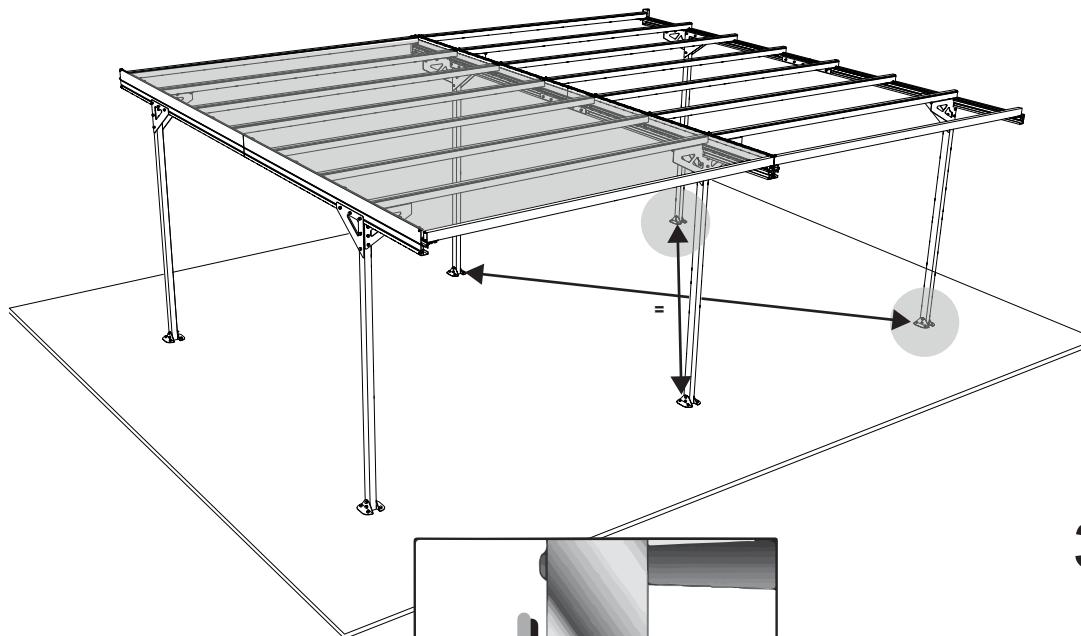

2

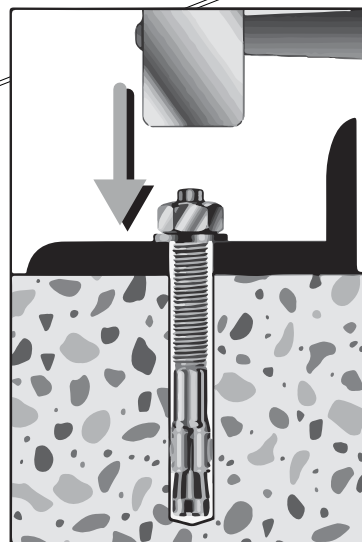

3

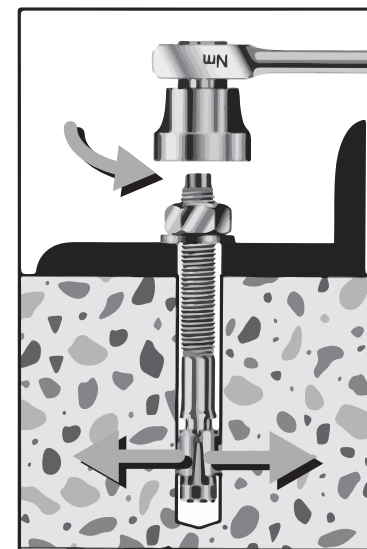

24

Etape 23 / Step 23

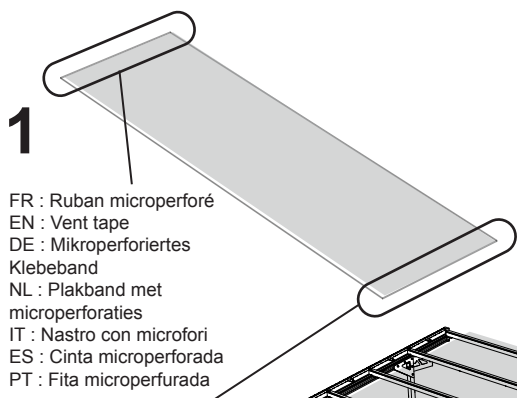
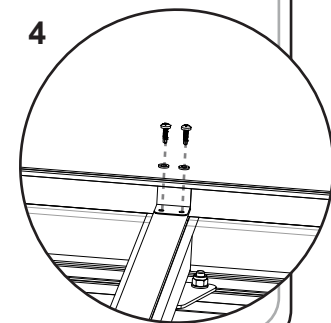
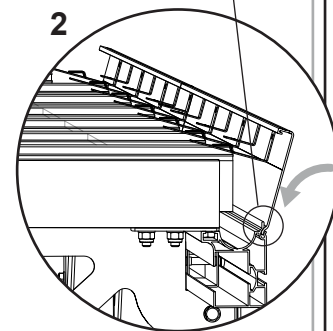
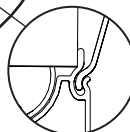
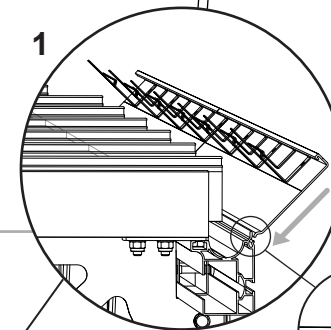
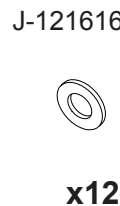
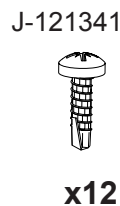
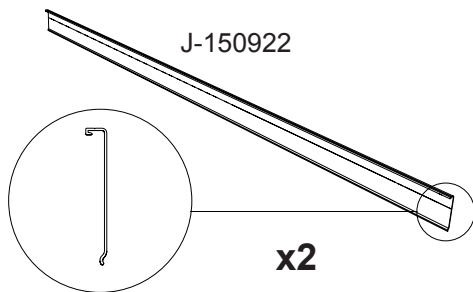
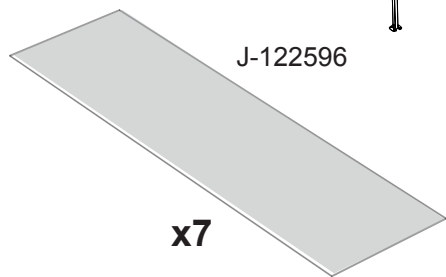
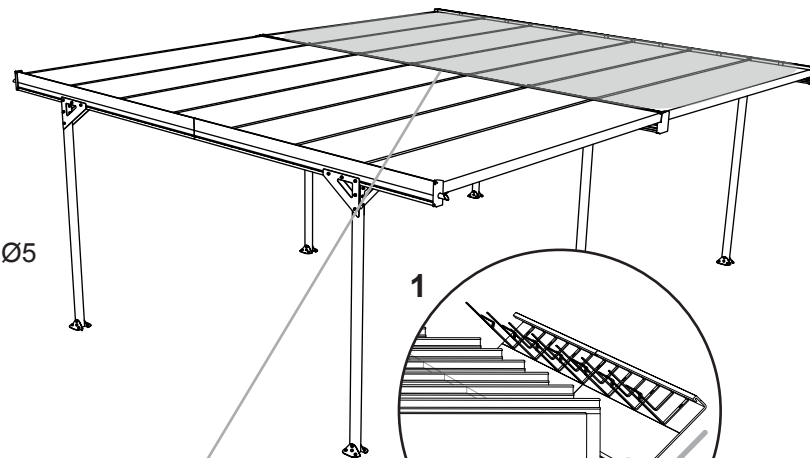
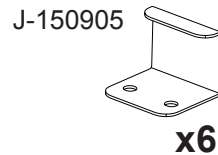
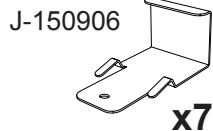
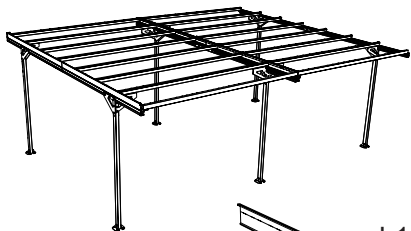

FR : Ruban microperforé
EN : Vent tape
DE : Mikroperforiertes Klebeband
NL : Plakband met microperforaties
IT : Nastro con microfori
ES : Cinta microperforada
PT : Fita microperfurada

3

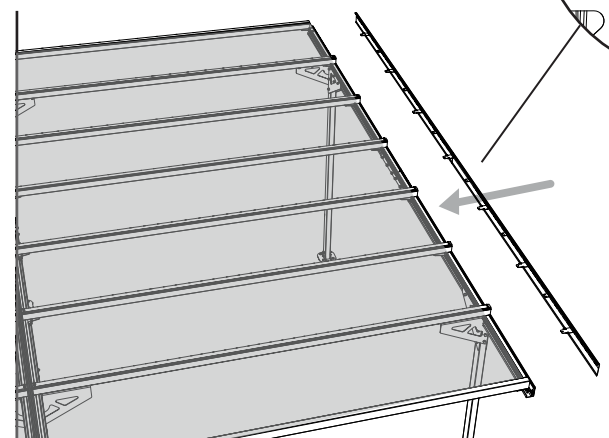

2

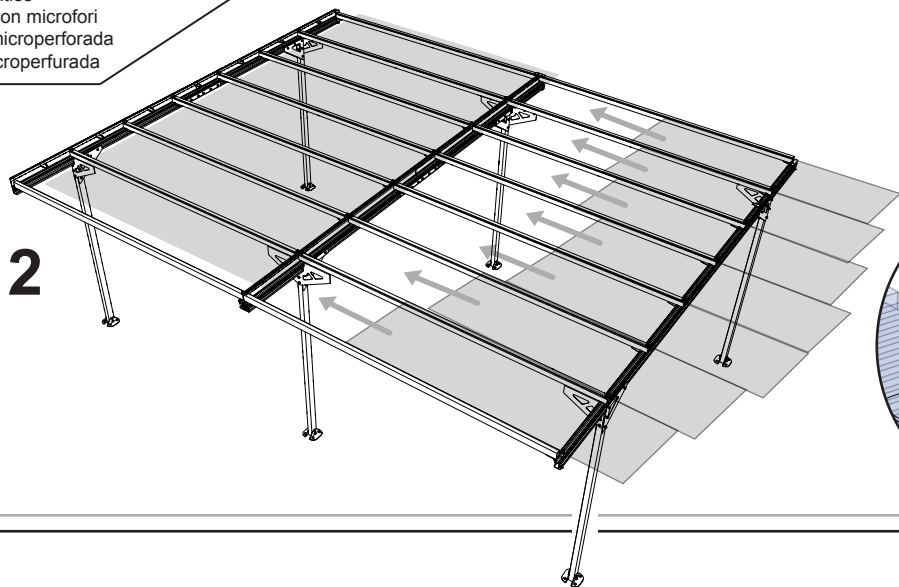

3

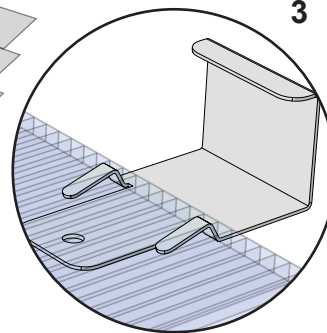

FR : Les pattes de l'attache s'insèrent dans les alvéoles
EN : The fixing supports slide in between the connective ribbing
DE : Die Befestigungslaschen werden in die Öffnungen eingeführt
NL : De haakjes van het bevestigingsstuk moeten in de openingen worden geschoven
IT : Le piastre di aggancio si inseriscono nelle apposite aperture
ES : Las patillas de unión se introducen en las cavidades
PT : Os ganchos de fixação devem ser inseridos nos alvéolos

25

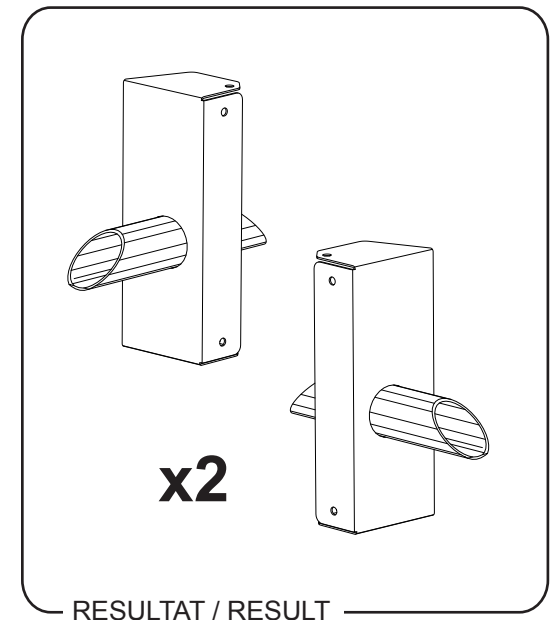
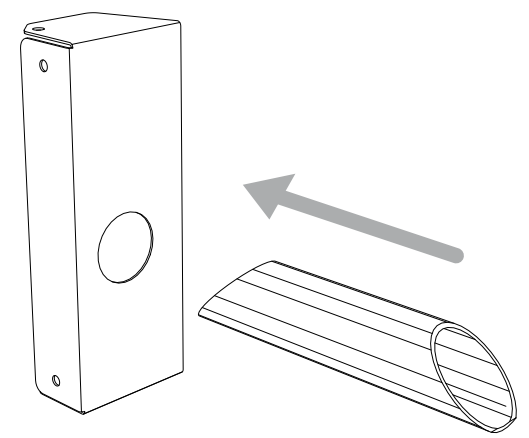
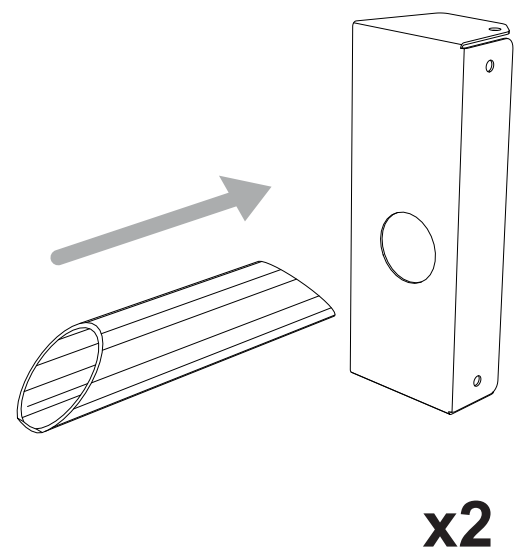
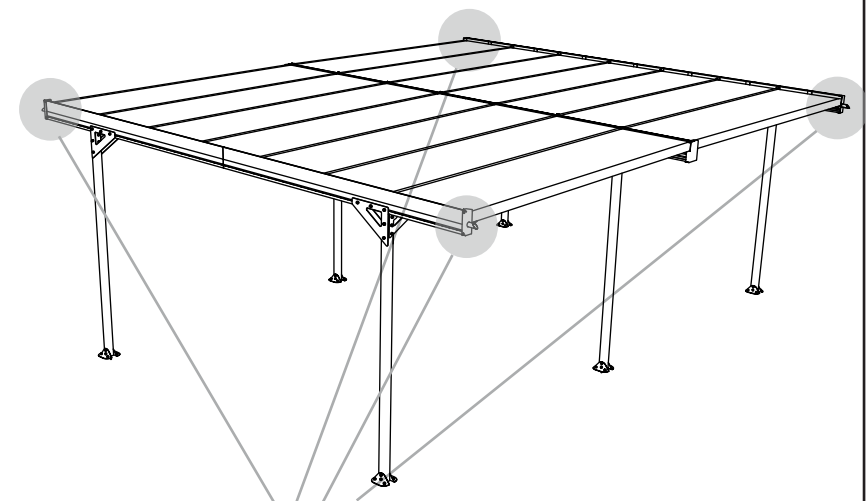
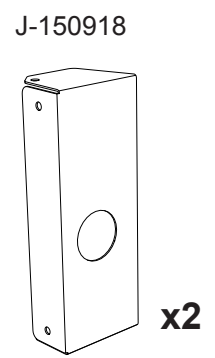
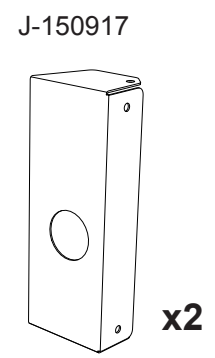
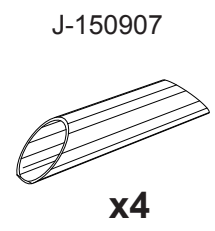

26

Etape 25 / Step 25

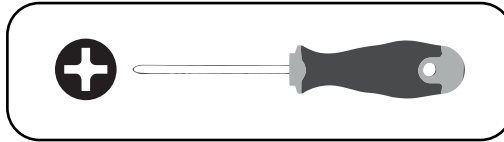
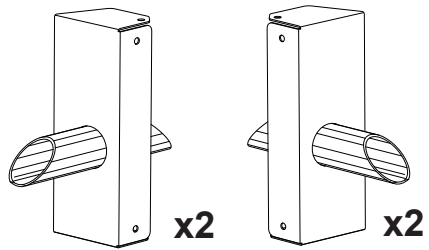

J-121341 J-121616 Ø5

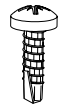

x20



x20

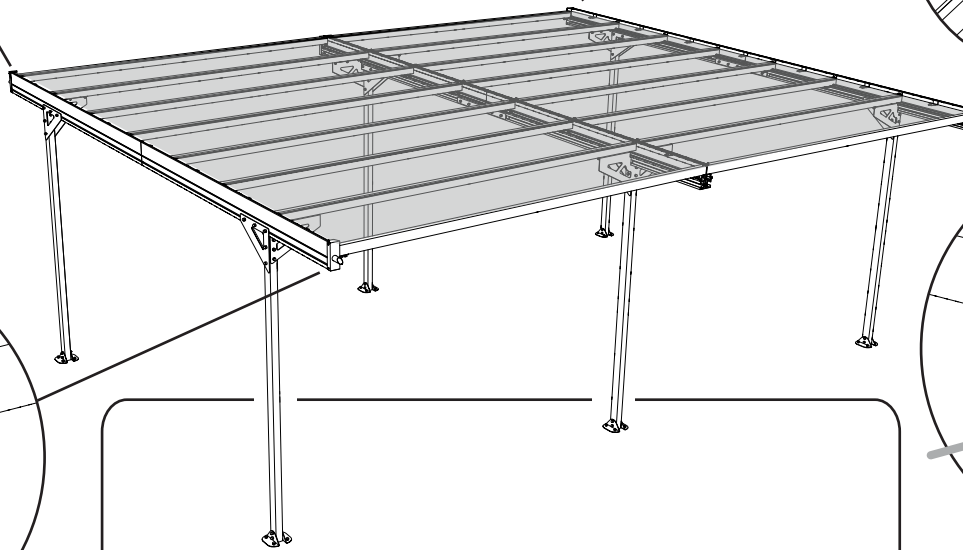
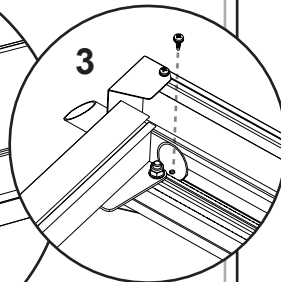
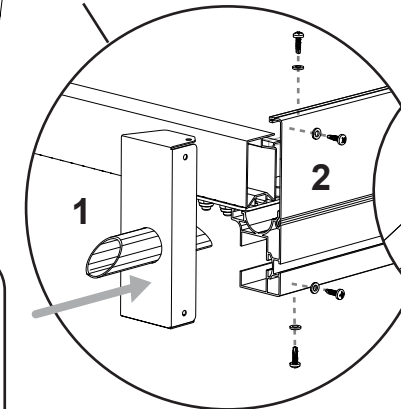
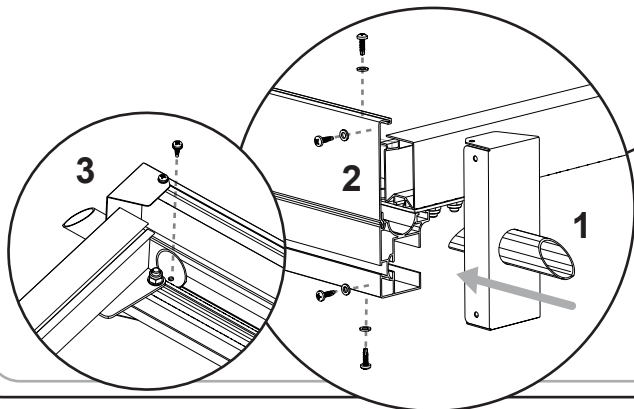
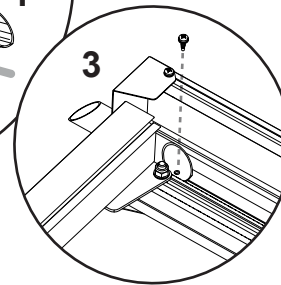
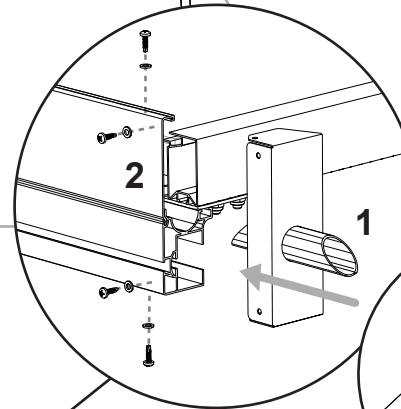
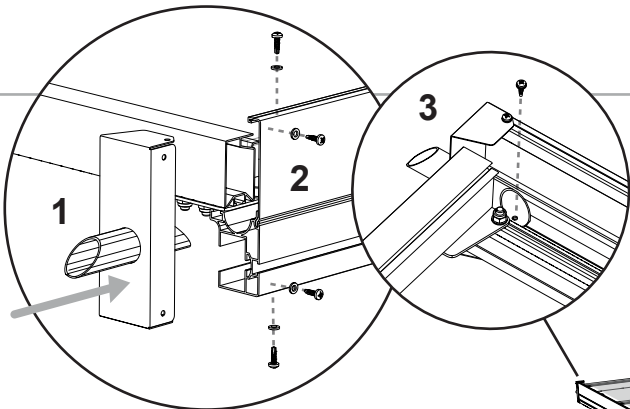

RESULTAT / RESULT

27

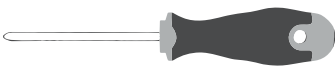

J-150924

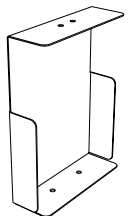

x2

J-121341

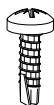

x8

J-121616 Ø5



x8

J-122594

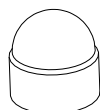

x280

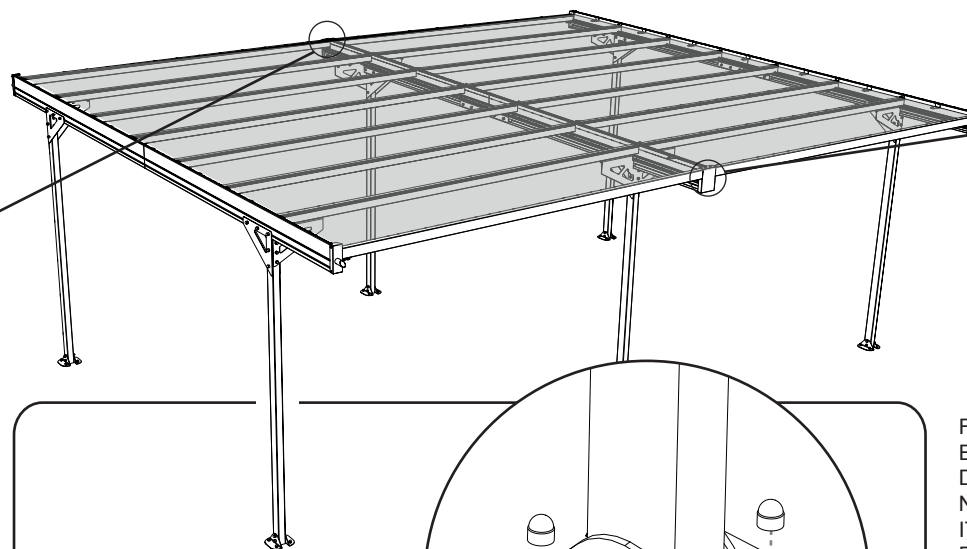
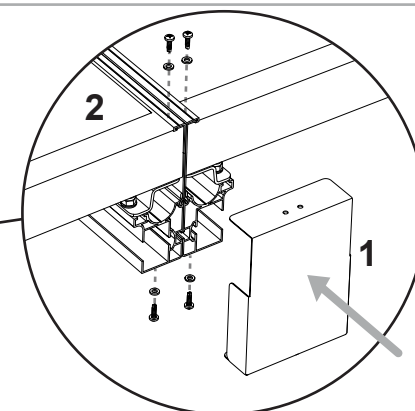
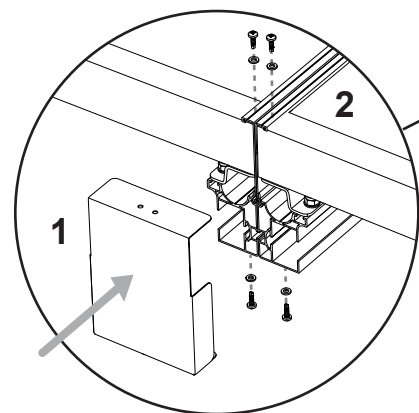
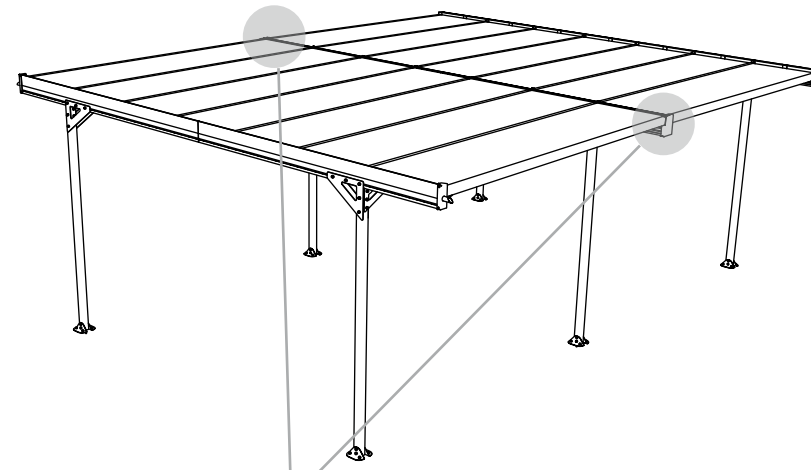

RESULTAT / RESULT

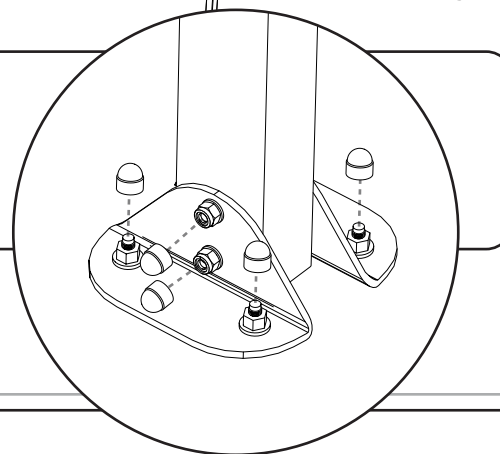

FR : Mettre les caches écrous sur l'ensemble des écrous
 EN : Fix the nut covers on all the nuts
 DE : Montieren Sie die Kappen auf allen Muttern
 NL : Bedek alle moeren met de moerkapjes
 IT : Applicare i copridado a tutti i dadi
 ES : Coloque los embellecedores en todas las tuercas
 PT : Colocar proteções de porcas em todas as porcas